

8 7 6 5 4 3 2 1

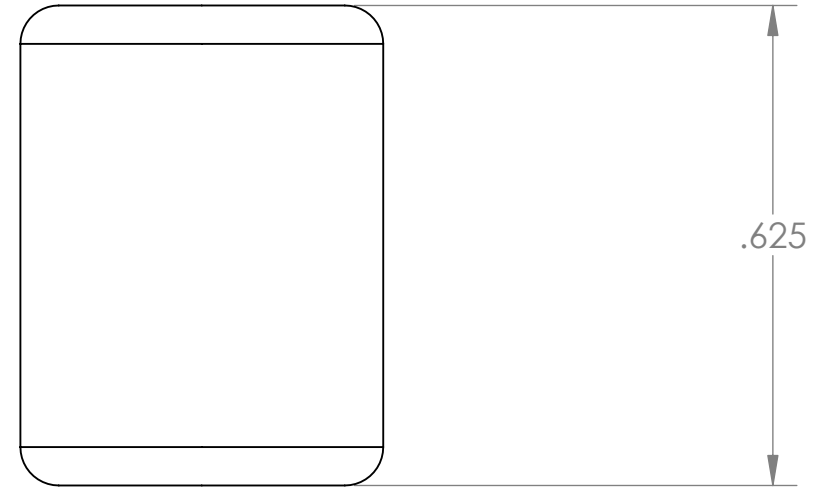
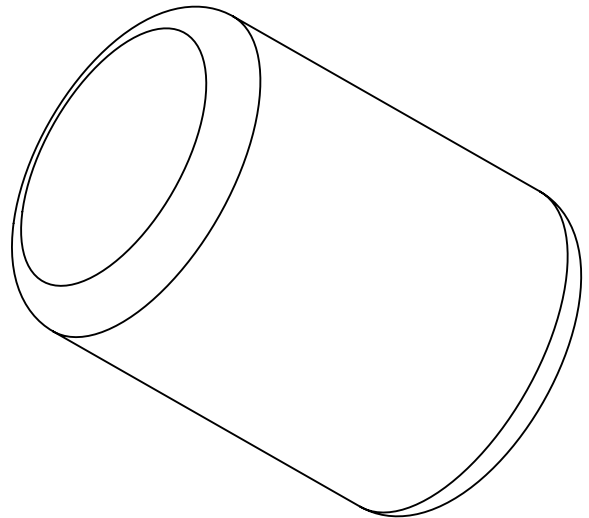
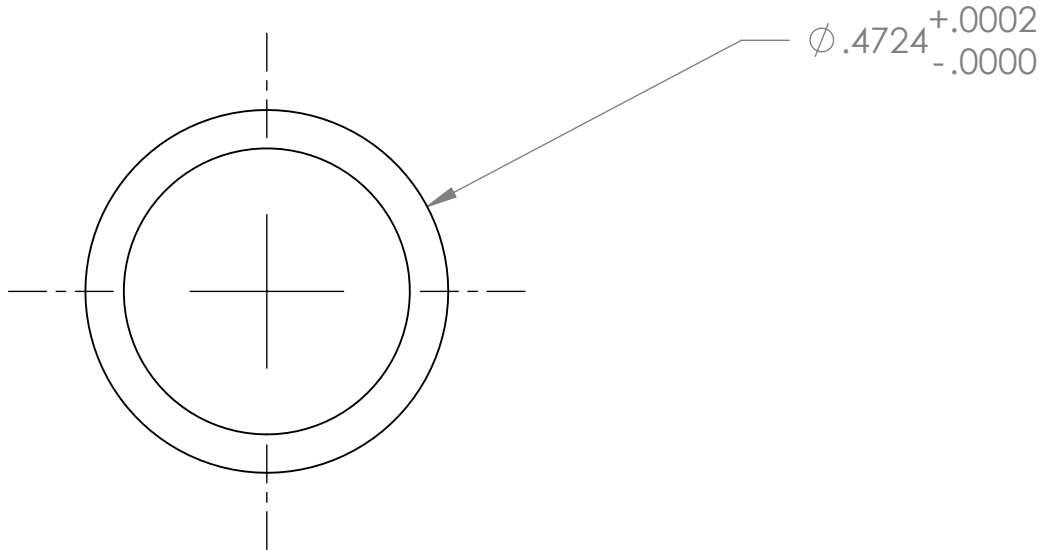

D  
C  
B  
A

D  
C  
B  
A

**PROPRIETARY AND CONFIDENTIAL**  
 THE INFORMATION CONTAINED IN THIS DRAWING IS THE SOLE PROPERTY OF <INSERT COMPANY NAME HERE>. ANY REPRODUCTION IN PART OR AS A WHOLE WITHOUT THE WRITTEN PERMISSION OF <INSERT COMPANY NAME HERE> IS PROHIBITED.

		UNLESS OTHERWISE SPECIFIED:		NAME	DATE
		DIMENSIONS ARE IN INCHES TOLERANCES: FRACTIONAL $\pm$ ANGULAR: MACH $\pm$ BEND $\pm$ TWO PLACE DECIMAL $\pm$ THREE PLACE DECIMAL $\pm$		DRAWN	
		INTERPRET GEOMETRIC TOLERANCING PER:		CHECKED	
		MATERIAL <b>Steel</b>		ENG APPR.	
NEXT ASSY	USED ON	FINISH		MFG APPR.	
APPLICATION		DO NOT SCALE DRAWING		Q.A.	
				COMMENTS:	
				TITLE: <b>Pin, 12 mm</b>	
		SIZE <b>B</b>	DWG. NO.	REV	
		SCALE: 4:1	WEIGHT:	SHEET 1 OF 1	

8 7 6 5 4 3 2 1