



CONSTANT SPEED PROPELLERS

MADE IN ITALY

IN FLIGHT ADJUSTABLE PITCH HUB KIT

TYPE:QA3WD005.....

S/N: _XXXXX_

BLD _XXXXXXXXX_

CONTROLLER TYPE _XXXXXXXX_

MANUAL

WARNING!

THE HUB DEVICE KIT IS NOT CERTIFIED AND IS NOT APPROVED BY FAA, BY PFA OR BY OTHERS AUTHORITIES. IT HAS NOT RECEIVED ANY SAFETY OR DURABILITY TESTING APPROVAL, AND DOES NOT CONFORMS TO NO AIRCRAFT STANDARDS. ITS USE IN STANDARD CATEGORY AIRCRAFT IS PROHIBITED. IT IS INTENDED FOR USE IN EXPERIMENTAL, UNCERTIFICATED AIRCRAFT IN WHICH AN HUB/PROPELLER FAILURE OR BREAKAGE , WILL NOT COMPROMISE SAFETY. USER ASSUMES ALL RISK OF USE, AND ACKNOWLEDGES BY HIS USE THAT HE KNOWS THE STATED LIMITS. .

TEL. 0575-842129 FAX 0575-842374

E-MAIL: QUINTI@SISTED.IT

WWW.QUINTIAVIO.COM

brevettato

AREZZO - ITALY

Warning: Flyers should be aware of the risks to which they expose themselves. It is good practice to take every and all safety precautions to minimize risk, while knowing that it cannot be eliminated altogether. A propeller malfunction could be cause for an emergency landing, or create vibrations severe enough to damage the aircraft. Propellers are constantly subject to vibrations deriving from the motor and aerodynamic forces, in addition, they are subject to further stress from centrifugal forces.

Because of this, it is essential that the propeller be maintained in accordance with the guidelines set forth in this manual, and that it be inspected regularly in order to identify any minor issues which if left ignored could become larger problems. Any grease escape, new vibration, or any deviance in typical functioning, must be investigated as it could be an indication of something serious which must be resolved.

We recommend a thorough read-through of this manual as it contains all information relevant to your new propeller. We especially request a careful reading of the sections dedicated to inspections and controls.

Thank you for choosing a Quinti Avio propeller. If properly inspected and maintained, it will grant you safe and reliable service.

General Index:

1. General Information:
 - 1.1 Definition of Components Duration
 - 1.1.1 Overhaul
 - 1.1.2 Repairs
 - 1.1.3 Components duration
 - 1.2 Introduction
2. Product Warranty Conditions:
3. Nomenclature / Part Identification
 - 3.1 Hub Nomenclature
 - 3.2 Numbering the blades up to 120 HP and HPT (HIGH POWER TYPE) up to 160 HP
4. Hub Technical Specifications
 - 4.1 Rotax Hubs, available for 912, 912S, 914T.
 - 4.2 SAE no. 1 type hubs available for Subaru EJ25 Eggenfellner rated at 160 HP
 - 4.3 SAE no. 2 type hubs available for Subaru H6 Eggenfellner rated at 200 HP
5. Installation instructions
 - 5.1 Preparation
 - 5.2 Installation Procedures
 - 5.3 Installing Brush Set
 - 5.3.1 Brush Set for hubs with slip ring pre-installed on hub (ROTAX)
 - 5.3.2 Brush Set for hubs with slip ring to be installed on engine gearbox (ROTAX)
 - 5.3.3 Brush Set for Slip Ring equipped hubs for gearbox installation on SUBARU
 - 5.4 Hub Set Installation Instructions
 - 5.4.1 Rotax Hub Set
 - 5.4.2 Instructions for Subaru Eggenfeller Hub Type Installation
 - 5.5 Blade Assembly Installation
 - 5.5.1 Propeller Balancing
 - 5.6 Installing the *FLY* manual governor (non constant-speed)
 - 5.6.1 General Information
 - 5.6.2 Installing the *FLY* control unit on the dashboard using a std. 2”1/4 diameter hole.
 - 5.6.3 Regulating minimum pitch using the manual switch
 - 5.7 Installing *Flyspeed GV* on the instrument panel
 - 5.7.1 General information
 - 5.7.2 Regulating minimum pitch using the manual switch
 - 5.7.3 RPM Sensor and Magnet Support Pylon installation
 - 5.7.3.1 Hubs with flange mounted pre-assembled Slip Ring
 - 5.7.3.2 Hubs with the Slip Ring mounted on the propeller gearbox
 - 5.7.4 Installing *Flyspeed GV* on the instrument panel
 - 5.7.4.1 General Information
 - 5.7.4.2 Technical Specifications
 - 5.7.4.3 Connecting *Flyspeed GV* to the Hub’s electric motor
 - 5.7.4.4 Connecting the intake manifold pressure tube (DMP)

5.7.4.5 Initial *Flyspeed* GV power-up

5.7.5 Preset Parameters and Customization

5.8 Operational Guidelines

5.8.1 General concepts for *Flyspeed* GV use with standard hubs and DMP control

5.8.2 General concepts for *Flyspeed* GV use with special hubs and DMP control

5.8.3 OPERATIONAL GUIDELINES

5.8.4 Configuration setting and details

5.8.5 Trouble shooting

5.8.6 Preventive maintenance

5.8.7 Error messages

6.0 Emergency procedures

6.1 Manual *FLY* Pitch Control

6.2 *Flyspeed* Gv 7.1

7.0 Inspections, Maintenance, Repairs

7.1 Inspections and Maintenance

7.2 Repairs

8.0 Shipping and Storing

9.0 Special tools and materials

10.0 Electrical *flyspeed* diagrams

11.0 Spare parts manual

12.0 Exploded Drawing

13.0 Torque values

1. General Information:

1.1 Definition of Components Duration

1.1.1 Overhaul

Overhaul occurs periodically and involves: disassembly, components inspection, components maintenance/replacement and reassembly. The overhaul interval is determined by flight hours or calendar days, whichever comes first. During overhaul the hub must be completely disassembled and closely inspected for cracks, excessive wear, corrosion or any other anomaly. Certain parts must be rebuilt or replaced as specified.

Overhaul must be performed in accordance with specifications set forth in the overhaul manual E.P.O.M 1 . The overhaul service interval is specified in the service bulletin B.S.1.

No overhaul is required on the *Fly* and *Flyspeed GV* control units.

1.1.2 Repairs

Repairs are understood to be correction of minor problems occurring during normal use. Any repair does not include, and therefore preclude, the normal overhaul schedule.

The type and severity of any damage will determine whether a full overhaul is necessary or not. For example, damage to a blade due to a ground strike will always require an overhaul.

1.1.3 Components duration

Expected parts lifetime is expressed in hours of use (**Total Time= TT**) and in hours since overhaul (**Time Since Overhaul = TSO**).

Both values are important to determining component duration. Certain components may have a limited lifetime, meaning they must be replaced after a specified time in use. All limited-life components are listed on the overhaul manual E.P.O.M. 1.

An overhaul will bring all parts to zero hours **TSO** (**time since overhaul**).
Total Time (**TT**) is unaffected by an overhaul.

1.2 Introduction

Quinti Avio's propellers have been designed to maximize performance in all phases of flight: take-off, climb, cruise, max leveled speed, descent and landing. Currently carbon blades produced by the US based *Warp Drive* are used. Pitch increase and decrease is produced along the blade's longitudinal axis by an electric motor rotating a main screw at the center of the hub. The rotating screw moves a mechanism at the base of each blade, which enacts the pitch variation.

Compared to most propellers on the market, Quinti Avio props boast quick pitch control movement. Such movement approaches that achieved by hydraulically controlled variable pitch hubs, which allow for constant propeller speed regardless of engine RPM. Typically electric hubs achieve relatively low pitch variation speeds of ca. $1^\circ/\text{sec}$. which translates to a performance loss compared to hydraulic hubs. Quinti Avio props distinguish themselves by approaching hydraulic hub performance with electric hubs; the standard version achieves ca. $2^\circ/\text{sec}$. (in continuous motion) therefore doubling typical electric hub performance. On certain special settings like reverse, full feathering, and High Performance, blade pitch variation occurs at ca. $3.5^\circ/\text{sec}$. (in continuous motion). Another unique characteristic of Quinti Avio's props is that they employ mechanical slide limiters rather than electrical ones. This is made possible by precision engineering and an innovative electronic constant speed control system: *Flyspeed GV*.

Flyspeed GV is an evolution of normal constant speed, variable pitch electric governors and can be thought of as "programmed power and constant speed" by automatically selecting more than 10 pre-set power settings, from a slow descent to a fast climb. *Flyspeed GV* uses a differential sensor to monitor Manifold Air Pressure (MAP). Intake manifold pressure is constantly compared to atmospheric pressure, yielding a value, which is used to elaborate throttle setting. The DMP setting, constantly visible on the *Flyspeed GV* display, stands for Differential Manifold Pressure and is achieved subtracting the pressure differential from 30.0 inches. Hence DMP corresponds to MAP only when the ambient pressure is 30.0 inches. At full throttle, and all altitudes, DMP will be between 29.2 and 29.5 inches. With a throttle setting below 30% power, DMP will be beneath 20.0 inches.

Flyspeed GV works based on existing conditions and pilot intentions. The primary pilot intentions are:

- 1) Intention to take off
- 2) Intention to land
- 3) Sure to land
- 4) Intention to abort landing

2. Product Warranty Conditions:

The warranty period is:

- All parts composing new propellers supplied by Quinti Avio srl are warranted for a period of 24 months from the date of shipment or 200 hours of operation, whichever comes first.
- All accessories supplied by Quinti Avio srl are warranted for a period of three months from the date of shipment or 50 hours of operation, whichever comes first.

Warranty benefits are subject to the following terms and conditions:

- All parts and/or accessories must be installed and used in accordance with the guidelines in the operating manuals and under normal operating conditions.
- Parts and/or accessories are not to be repaired or modified outside of direct supervision by Quinti Avio srl.
- Parts and/or accessories cannot have been damaged as a result of excessive wear, improper use, negligence, accident, or in speed conditions in excess of the guidelines set forth by the manufacturer.
- Damaged parts and/or accessories should be returned to Quinti Avio srl. via pre-paid courier.

Quinti Avio srl's obligations under this warranty, do not extend to the labor costs associated with substituting parts, making repairs, making adjustments, or any other work on any propeller.

The client accepts that the rights and benefits as expressed in this warranty, represent the complete extent to which Quinti Avio srl. is held responsible relative to the client. Including all expressed and implicit guarantees and all other obligations and any responsibility on the part of Quinti Avio srl. relative to contractual and civil obligations.

The warranty is specific to the owner and non-transferable. In case the original owner sells or otherwise disposes of the parts and/or accessories to a third party, the owner must notify the third party that Quinti Avio Srl. will make a separate accord of warranty with the third party in the form here represented

The owner assumes all responsibility concerning installation procedures, proper installation, operation, maintenance, inspection, repair and upgrades of the propeller and any accessories.

As a function of customer service, not a warranty service, Quinti Avio's personnel and representatives of Quinti Avio. are available to answer any questions regarding individual use applications. All questions should be accompanied by client address, propeller model and serial number, Total Time and any other relevant details.

This manual will be periodically upgraded on web. You will find on the web too all the information regarding mandatory upgrades to the products. The customer will pawn his self to make upgrade to proper products. Parts for upgrade will be in charge to the costumer.

3. Nomenclature / Part Identification

3.1 Hub Nomenclature

Example: QA3WD001R001

- QA : Identifies the manufacturer
- 3 or 2 : Identifies se the hub as 3-bladed or 2-bladed
- WD : Identifies the blade manufacturer (Warp Drive)
- 001 : Identifies the manufacturing batch (001)
- R or S : Identifies the type of hub drilling for Rotax or SAE no.1
- 001 : Identifies version: standard, hi performance, extension, for Rotax engines with or without vacuum pump)
- IT0001 : Identifies the hub's serial number (IT= ITALY ; US= USA ; etc.)

3.2 Numbering the blades up to 120 HP and HPT (HIGH POWER TYPE) up to 160 HP

The blade's serial number is assigned by the blade's manufacturer (Warp Drive) by way of an adhesive plate on only one of the blades composing the set. The number identifies the type (T, C or N) and the set's number (ex: T8118). This alphanumeric value is repeated at the hub-side base of the blades along with the other alphanumeric values (2BL or 3BL) and (66", 68", 70", 72") which identify the number of blades and their length.

Example: C8018 - 3BL – 66

- C, T or N : Identifies the blade type:
 - C - standard blade, rectangular end
 - T - tapered blade
 - N – standard blade, nickel leading edgeIn the case a tapered blade has a nickel leading edge: "T"
- 8018 : Identifies the progressive set numbering, assigned by Warp Drive
- 2BL o 3BL : Identifies the set as 2-bladed or 3-bladed
- 66 : Identifies the propeller length in inches

4. Hub Technical Specifications

4.1 Rotax Hubs, available for 912, 912S, 914T.

Hubs with “Rotax” type mounting flange: no.6 holes for 13mm Ø pins set on a diameter of 4 in. (101.6 mm) and a centering hole of 47 mm Ø.

Max power applicable only with engines equipped with gearbox.

Type	no. of blades	max kW/ max. HP	max. RPM	pitch range			Kg / lbs
				Degrees			
				Std	Rev	feath	
QA2WD...R	2	60/ 80	2800	20°	55°	80°	8.4 / 18.50
QA3WD...R	3	90/120	2800	20°	55°	80°	10.7 / 23.54

4.2 SAE no. 1 type hubs available for Subaru EJ25 Eggenfellner rated at 160 HP

“SAE 1” type mounting flange : no.6 holes 5/8 in. Ø pins (15.87 mm) set on a diameter of 4 ¾ in. (111.125 mm), and a centering hole of 2 ¼ in. Ø (57.15 mm)

Max power applicable only with engines equipped with gearbox and high power blades “HPT”.

Type	no. of blades	max kW/ max. HP	max. RPM	pitch range			Kg / lbs
				Degrees			
				Std	Rev	feath	
QA3WD...S	3	120/160	2800	20°	55°	80°	11.3 / 24.90

4.3 SAE no. 2 type hubs available for Subaru H6 Eggenfellner rated at 200 HP

“SAE 2” type mounting flange : no.6 holes 5/8 in. Ø pins (15.87 mm) set on a diameter of 4 6/8 in. (120.65 mm), and a centering hole of 2 ¼ in. Ø (57.15 mm)

Max power applicable only with engines equipped with gearbox and high power blades “HPT”.

Type	no. of blades	max kW/ max. HP	max. RPM	pitch range			Kg / lbs
				Degrees			
				Std	Rev	feath	
QA4WD...S	4	150/200	2800	20°	55°	80°	15.5 / 34.15

- All weight values are without spinner plate and spinner which typically is ca. 1Kg.
- Propeller diameters mounting Warp Drive blades are between 42in. and 72in.
- All weight values are achieved using 64in. blade diameters. Blade length will affect overall weight.

Warning:

- *Manufacturer approval is required to install on engines other than those listed above.*
- *Acrobatic, semi-acrobatic and extreme maneuvers are not allowed.*

5. Installation instructions

5.1 Preparation

In order to avoid problems relating to the improper installation and consequently improper functioning of your new propeller, we strongly recommend you perform the following check on your aircraft:

- Verify proper carburation jetting
- Verify carburator balancing/synchronization
- Verify proper gearbox functionality; on Rotax engines carefully verify spring preload. The gearbox must be equipped with internal clutch as are all certified Rotax engines.
- Be sure that the air ducts and airbox are not wholly or partially obstructed. Verify that full RPM and full Manifold Pressure are achieved at max throttle setting.
- Carefully clean all surfaces of the engine flange mount with a mild solvent. Verify that the flange has not been previously damaged by a blade ground strike by having the *run-out* from the centering point and the axial *run-out* inspected by a certified mechanic ensuring they are within the tolerance limits as set by the engine manufacturer. Also ensure that there are no visible deformations or cracks which will prevent a perfect contact between the hub and engine flanges. This inspection should also be performed on new engines.

Performing all of the above requisites will set us on the right course to achieving a correct propeller installation.

5.2 Installation Procedures

Before beginning the installation, carefully check the materials as you remove them from the original packaging. Check the spinner plate, the spinner, the electrical group, the electric motor, the prop speed governor, the connecting flange, the blade mounts and the blades. The propeller kit arrives to the client divided into 4 groups:

- Brush Set
- Hub Set
- Blade Set
- Fly or Flyspeed GV

5.3 Installing Brush Set

5.3.1 Brush Set for hubs with slip ring pre-installed on hub (ROTAX)

This Brush Set will be installed on the right front side of the gearbox, seeing the gearbox from the side of the engine flange mount, using the two M8 machined holes.

- Bolt the Brush Set using M8x25 screws along with Loctite 222 gripping agent. Place the brush holders and brushes on the slip ring directly above the metal tracks, make them touch, making sure they are centered. Pre-load the brushes on the slip ring rotating the center cam: apply medium tension to allow for standard brush wear. Pre-loading excessively will result in faster wear. Insufficient pre-load will result in increasingly lighter contact pressure as wear reduces the brushes thickness, a condition which in time could compromise the transfer of current and consequently blade pitch control.
- Before final tightening of the brushes mounting, be sure that the brushes slide exclusively along the slip ring's metal tracks by manually rotating the propeller. Repeat until correctly positioned. Once the positioning is correct, tighten the brushes support via the M6x25 screw, once again using a gripping agent like Loctite222 or similar.

Caution: Before manually rotating the propeller ensure that both L & R magnetos are in the OFF position in order to avoid inadvertently starting the engine. Is it absolutely unacceptable for the brushes to make contact outside of the metallic tracks.

Caution: If necessary cut the engine cowling to ensure there is no physical contact between it and the brush set. We recommend leaving as much space as possible to allow for natural engine oscillation. Be sure that when making modifications to the engine cowling, you do not inadvertently create openings or gaps outside of the spinner's aerodynamic 'shadow'.

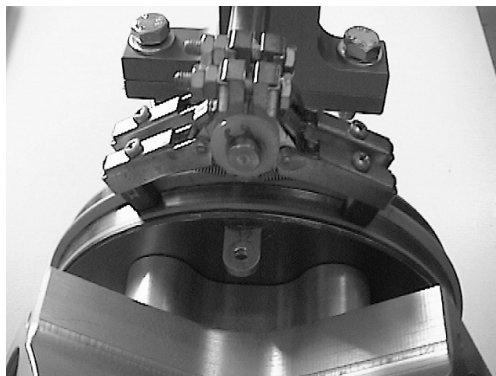

5.3.2 Brush Set for hubs with slip ring to be installed on engine gearbox (ROTAX)

- Insert the slip ring wires from the back side of the gearbox, through the engine block flange passing hole, until the slip ring reaches and engages the appropriate notch in the engine block flange.
- Install the M4 screw bolt on the top side of the gearbox mounting, after having passed the slip ring wires through the appropriate holes on the mounting bracket. At the same time ensure the M4 anchoring bolt passes through to the opposite side of the gearbox.
- Tighten the anchoring bolt by adding a washer and self tightening M4 lug-nut to the opposite side, ensure the gearbox is properly tightened.
- Add two fasteners to the wire ends.
- Install the brush mounting bracket on the back side of the gearbox using the two M6 screw-bolt mounting holes and M6x25 bolts, apply a gripping agent such as Loctite 222. Ensure that the brushes match up with the metal tracks on the slip ring.

Caution: Before manually rotating the propeller ensure that both L & R magnetos are in the OFF position in order to avoid inadvertently starting the engine. Is it absolutely unacceptable for the brushes to make contact outside of the metallic tracks.

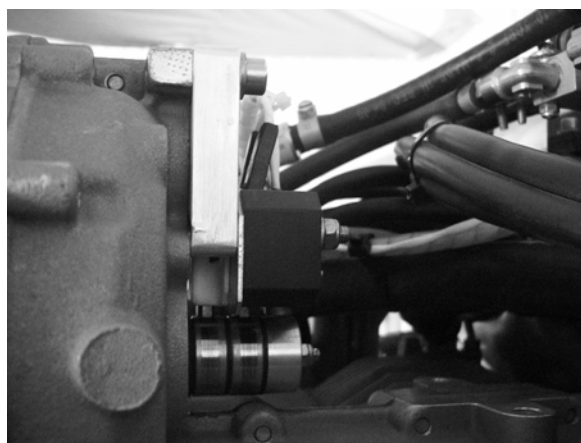

5.3.3 Brush Set for Slip Ring equipped hubs for gearbox installation on SUBARU engines.

This sensor group will be installed on the front right side of the gearbox, seeing the gearbox from the engine flange side, using the two screw-holes on the aluminum plate of the gearbox.

- Mount the brush mounting bracket with the appropriate screws and using a gripping agent such as Loctite 222. Place the brush arms on the slip ring, carefully lining them up with the tracks. Pre-load the brushes on the slip ring rotating the center cam: apply medium tension to allow for standard brush wear. Pre-loading excessively will result in faster wear. Insufficient pre-load will result in increasingly lighter contact pressure as wear reduces the brush thickness, a condition which in time could compromise the transfer of current and consequently blade pitch control.
- Before final tightening of the brush mounting, be sure that the brush slide exclusively along the slip ring's metal tracks by manually rotating the propeller. Repeat until correctly positioned. Once the positioning is correct, tighten the brush support via the M6x25 screw, once again using a gripping agent like Loctite222 or similar.

Caution: Before manually rotating the propeller ensure that both L & R magnetos are in the OFF position in order to avoid inadvertently starting the engine. Is it absolutely unacceptable for the brush mountings to make contact outside of the metallic tracks.

Caution: If necessary cut the engine cowling to ensure there is no physical contact between it and the brush set. We recommend leaving as much space as possible to allow for natural engine oscillation. Be sure that when making modifications to the engine cowling, you do not inadvertently create openings or gaps outside of the spinner's aerodynamic 'shadow'.

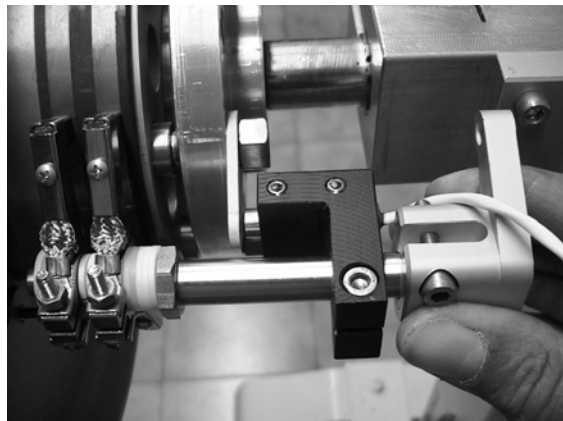

5.4 Hub Set Installation Instructions

5.4.1 Rotax Hub Set

- Remove the six original engine flange tightening bolts and replace with the six tightening bolts provided in the kit. Ensure a proper seal is regained when tightening, space between any parts is not allowed.
- Carefully clean all contact surfaces (engine flange and propeller flange).
- Mount the Hub Set first without the blades or the spinner, ensure the guide notches are well matched up between the hub and the engine flange. With the slip ring mounted behind the gearbox, connect the hub wires with the slip ring wires passing them through the center of the engine mounting flange. Ensure the hub is properly aligned with the principal axis, and is matched up completely with all parts touching.

Caution: *In the case of hub installations described in section 5.3.2, exercise caution while sliding the various parts into position. Ensure that all wires are carefully wound and completely inside the engine flange cavity to ensure they are not accidentally damaged while positioning the parts.*

- Next install six washers and M8 self-blocking lug nuts to the six fastening bolts, tightening carefully and lightly in an 'x' pattern, until the hub and engine flanges are completely in adherence. Finally tighten the lug-nuts employing a torque wrench being careful to avoid excessive tightening which could result in thread damage to the hub which could result in a general weakening of the part.

Caution: *If you are installing a hub with directly mounted slip ring, you must install the included magnet mounting pylon beneath one of the six M8 mounting bolts only when using the Flyspeed GV. In this case do not tighten the one bolt hosting the mounting pylon, as it will need to be positioned and tightened only after the brush installation has occurred. In all other cases the mounting pylon will not be necessary as it is incorporated into the slip ring.*

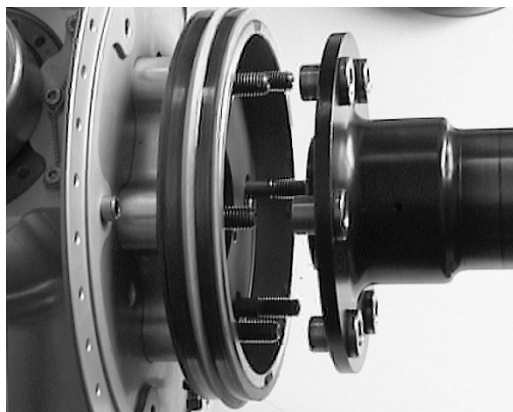

5.4.2 Instructions for Subaru Eggenfeller Hub Type Installation

- Subaru Eggenfeller engine mounts do not have mounting bolts; rather they have cavities for 5/8 inch bolts. If you have said bolts, they should be removed.
- Ensure that the hub has the slip ring pre-installed and the six 5/8" bolts are already inserted. These bolts have reduced diameter on a portion to allow them to properly lodge within the engine flange. Ensure during installation that you use the correct parts.
- Carefully clean all contact surfaces (engine flange, propeller flange, slip ring flange).
- Mount the hub-gearbox-spinner plate assembly, without the blades yet mounted, on the engine flange being careful to properly line-up the mounting bolts and their holes. Slide the hub carefully into position. Ensure the hub is properly aligned with the principal axis, and is matched up completely with all parts touching.
- Next install six washers and 3/8"-24 self-blocking lug nuts to the six fastening bolts, tightening carefully and lightly in an 'x' pattern, until the hub and engine flanges are completely in adherence. Finally tighten the lug-nuts employing a torque wrench being careful to avoid excessive tightening which could result in thread damage to the hub, which could result in a general weakening of the part.

Caution: *you must install the included magnet mounting pylon beneath one of the six 3/8"-24 mounting bolts only when using the Flyspeed GV. In this case do not tighten the one bolt hosting the mounting pylon, as it will need to be positioned and tightened only after the brush installation has occurred.*

5.5 Blade Assembly Installation

Once the hub set is mounted to the engine flange, ensure the blade mounting cavities; specifically the threading, the bearing contact surfaces and the o-ring slots. All must be in perfect condition. Repeat for each blade sleeve housing. Ensure that the blade steel mounting support that already has a bearing mounted, resists pressure, and has no superficial cracks or dings which could slow or block its rotation once mounted into the hub housing. Each hub housing is identified by a number corresponding the blade which it will host. The blade has the corresponding number on the aluminum sleeve.

- Vertically position one of the hub blade housings.
- Insert the bronze key provided with the kit (greased) into the steel spine of the hubs internal support structure, carefully sending it full run positioning it horizontally and parallel to the blade's mounting flange.
- Insert the o-ring from the kit (greased) in the specific notch at the end of the hub's blade housing next to the threading.
Install the ball bearing unit from the kit (greased) in the specific notch at the bottom of the hub's threaded housing cavity.
- Grease the entire blade housing cavity, including the threading which will host the blade itself.

- Take the blade with your left hand near the base, with the right hand take the aluminum sleeve. Ensure that the fitting at the base of the blade matches up with the bronze key you previously installed in the hub. Begin to screw-in the aluminum sleeve perpendicularly to the housing. Continue screwing the blade into place until you are 2 or 3 threads from completion, at this point you should guide the bronze key into place by applying downward pressure on the blade while simultaneously rotating it back and forth. You'll be sure of having fitted the key into place properly once the blade descends further into place and can no longer move at an angle. At this point finish screwing the aluminum sleeve into place.

Caution: *The aluminum blade sleeve cannot extend out of the hub housing, if it does, this is an indication that the blade is not properly hosted in the hub, and the installation procedure needs to be repeated. Throughout the installation make sure that the o-ring remains in place.*

- With the particular wrench included in the kit, tighten the aluminum blade sleeve using a torque wrench. We recommend 2 or 3 tightening/loosening cycles in order to expel all the excess grease from the hub blade housing and the blade itself. Once that has occurred tighten for the last time at the recommended torque setting.

Caution: *Axial play between coupled parts is not allowable.*

- Install the provided safety lock which will prevent inadvertent blade/sleeve separation. Place the lock by lining up at the bolts on the hub's rim, tighten with washers and self-blocking lug-nuts. The bolt on the aluminum sleeve does not require a self-blocking lug-nut.
- Repeat the procedure for each blade.

Caution: Once the propeller installation is complete, check aircraft weight and balance parameters to ensure that you have not exceeded the parameters as set forth in the aircraft user manual.

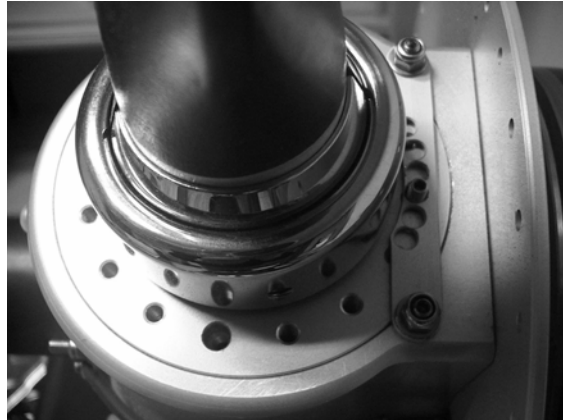

5.5.1 Propeller Balancing

Balancing the propeller is required in order to avoid the possible waving of warranty coverage. We recommend the use of the most accurate instruments available to identify the extent and location of any imbalance. Once identified and addressed, the remaining imbalance must be equal to or less than 0.20 IPS (inches per second). If the initial imbalance value is 1.20 IPS or greater, the propeller must be removed from the aircraft and balanced statically before being re-balanced dynamically. We recommend weight placement in a radial pattering on the spinner plate.

5.6 Installing the *FLY* manual governor (non constant-speed)

5.6.1 General Information

- The *FLY* manual control unit consists of a double-polarity switch which sends electric current of opposite polarity depending on the switch position (UP, DOWN) which activates the electric motor in a clockwise or counter-clockwise direction, resulting in an increase or decrease of blade pitch angle. This controller doses current to the electric motor through a resistance unit, to avoid damage to the motor when the blades reach the end of their pitch range.

5.6.2 Installing the *FLY* control unit on the dashboard using a std. 2”1/4 diameter hole.

- Verify proper blade movement on the ground with the engine off: when the *FLY* switch is held in the *down (fine pitch)* position the blades reduce pitch angle and the amber *led* illuminates; when the switch is held in the *up (coarse pitch)* position the blades increase pitch angle and the green *led* illuminates. When you reach maximum/minimum pitch angles the red *led* illuminates. If you verify exact opposite functionality, the wires connecting to the brush must have their positioning inverted.

Caution: Avoid maintaining pressure on the switch once the red led is illuminated, it is warning you that you have reached the end-run, and any insistence will unnecessarily deliver excessive current levels to the electric motor. We recommend to never allow the red led to be illuminated for more than 3-5 seconds.



5.6.3 Regulating minimum pitch using the manual switch

Caution: Before starting the engine, remove the spinner so as to simplify later adjustments. To ensure safety and reduce incidents choose a location, which is free and clear of objects, obstacles and people. Also, ensure that the area is devoid of gravel, sand and other materials which could be sucked into the path of the propeller potentially damaging it, and/or causing injury to you and others participating in the process.

- Verify max take-off RPM: with full brakes and chocked wheels, progressively apply full throttle. To avoid potentially going past red-line, we recommend starting with a moderate/high pitch setting. Max take-off RPM should be set, using the *FLY* switch, at approx 50 – 100 propeller RPM beneath max take-off RPM as specified in the aircraft operating manual or the engine operating manual.
- Once the correct RPM value is achieved, throttle back gently and switch the engine off. Regulate the three adjustment points surrounding the electric motor by carefully and uniformly sliding them to touch the support within the hub, this sets the physical end-run limits. Then tighten the adjustment points using the three self-blocking lug-nuts, do this carefully while keeping the adjustment points immobile with a Hallen wrench. In case of any doubts regarding the hub installation or the electric pitch control system, we ask that you contact the manufacturer or an authorized technician.

Caution: If the adjustment points are not properly registered, damage could occur as the rotating assymetry will result in greater current loads, greater friction of the movable parts, damage to the adjustment points themselves, and differences in pitch between the propeller blades.

Caution: The use of variable pitch propellers requires the presence of a Manifold Pressure Gauge. Consult the aircraft-operating manual for maximum RPM and Manifold Pressure combinations. Pay special attention to RPM settings that are permissible only for limited time periods. We recommend using red tape to identify on the RPM gauge directly, RPM settings that are to be avoided for extended periods of time. In addition the RPM gauge must be registered on an annual basis, and the accuracy should be within 50 RPM, consistent inaccuracy is cause to replace or repair the instrument.

Caution: In case of any doubts regarding the hub installation or the electric pitch control system, we ask that you contact the manufacturer or an authorized technician.

Caution: Never apply direct current to the hub's electric motor. Do so only through a Quinti Avio controller. Do not attempt to modify pitch without the blade being mounted, the end-runs could be damaged. Never use a battery charger to power the control unit, only use professional lab quality, stabilized power units that guarantee constant current output of 12 – 13.8V.

Caution: During the first installation and during overhaul, it is possible for a small quantity of grease to leak from the hub onto the spinner and blades; use a mild detergent to remove the grease in such cases. Any grease loss should end within 15 to 20 hours of operation.

5.7 Installing the Flyspeed GV constant speed governor

5.7.1 General Information



The *Flyspeed GV* constant speed governor is designed to optimize propeller performance in maximum safety. It evolves from typical electric constant speed governors and can be considered to be 'power programmed at constant speed' with the automatic selection of more than 10 pre-programmed cruise settings.

What separates the *Flyspeed GV* from other 'normal' governors is that it will choose the ideal RPM setting based upon an interpretation of throttle setting, while 'normal' governors will require the pilot to make that decision. The *Flyspeed GV* uses a differential sensor to monitor Manifold Air Pressure (MAP). Intake manifold pressure is constantly compared to atmospheric pressure, yielding a value that is used to elaborate throttle setting.

The DMP setting, constantly visible on the *Flyspeed GV* display, stands for Differential Manifold Pressure and is achieved subtracting the pressure differential from 30.0 inches. Hence DMP corresponds to MAP only when the ambient pressure is 30.0 inches. At full throttle, and all altitudes, DMP will be between 29.2 and 29.5 inches. With a throttle setting below 30% power, DMP will be beneath 20.0 inches.

Flyspeed GV works based on existing conditions and pilot intentions. The primary pilot intentions are:

- 1) Intention to take off
 - 2) Intention to land
 - 3) Sure to land
 - 4) Intention to abort landing
-
- 1) After completing a Prop Cycle, Blade pitch automatically settles on the TAKE OFF setting (T_OFF). Automatic pitch control will not occur until RPM values reach the set range as established by T_OFF. Example: if *Flyspeed GV* T_OFF RPM are set at 5800 and the broad range (set by COARSE HYST RPM) is set at 300 RPM, it will be necessary to achieve a minimum of 5501 RPM ($5800 - 300 = 5500$) to initiate automatic pitch control. In this case after a pre-established time interval (normally 20 seconds, as established by TAKE OFF TIME parameter) the CLIMB setting will automatically be inserted to avoid an excessive time period at 100% power setting (Ex: Rotax).

- 2) LAND DMP selects a low pitch setting, very close to T_OFF, thereby yielding moderate thrust, while allowing a smooth descent. This setting can be used for landing. By applying power this flight condition can be exited in order to extend a landing pattern or to remain in a holding pattern.
- 3) A more pronounced descent can be achieved by reducing power until IDLE appears on the *Flyspeed GV* display.
- 4) If the pilot applies full throttle, the increase in RPM to near T_OFF levels alerts the *Flyspeed GV* to an aborted landing. In this case the CLIMB preset will be engaged, which will allow maximum continuous power.

Comments: Unfortunately DMP cannot optimize all flight conditions. We could add additional sensors, such as altitude, temperature and humidity measurement, but this would result in excess complexity. It is however possible to obtain a programmed RPM 'shift' relative to DMP. *Flyspeed GV* will support constant speed even without DMP control, but this is possible only with particular hub motors and will be further explored in later sections of this manual.

Safety:

System overload protection is guaranteed in two ways. In the case of a malfunction due to an external electrical discharge or system anomaly non-responsive to off/on cycling, a specific emergency channel can be activated which bypasses the entire system. *Flyspeed GV* continuously monitors and limits current according to the limits as specified by the user. Additional protection for all modes of operation is provided by two solid-state fuses, one for *Flyspeed GV*'s general electronic protection, and the other for the emergency control channel.

Simplicity of Use:

After completing a Prop Cycle (CYCLE PROP, standard starting procedure/pre-flight), with DMP functionality on, DMP_ON, the *Flyspeed GV* can be utilized simply through normal manipulation of the throttle as when using a fixed pitch propeller. Alternatively, after CYCLE PROP, with DMP functionality off, DMP_OFF, the ▼▲ buttons can be used to select pre-programmed pitch settings for takeoff, climb, cruise, medium cruise, economic cruise, and landing while maintaining constant speed functionality. In MANUAL mode the ▼▲ buttons increase and decrease blade pitch.

Do not use in DMP OFF.

Customizing your *Flyspeed GV*:

A Personal Identification Code allows you to access additional functionality, specifically to modify configuration parameters such as response control, initial pitch setting, short-circuit threshold, DMP/RPM matrix modification, and others. We recommend you do not make modifications to Default settings without first receiving approval from the manufacturer.

More Options:

Flyspeed GV will function with full-feathering and reversing hubs. High Performance fast pitch change hubs are also compatible. High Performance propellers can be used in landing in braking effect.

Diagnostics and Error Resolution:

By connecting *Flyspeed GV* to a PC via serial port, you can access and download RPM, DMP, and electrical current data. This is helpful when optimizing motor control and prop pitch parameters.

System Components:

- Electronic Control and Display Units
- HALL type solid state RPM sensor, with plastic bracket
- All necessary wiring for hub motor, battery and sensors
- Neodymium magneto for use with the HALL magnetic sensor

Optional Installation and Diagnostic Accessories:

- PC Interface Cable (serial DB9)
- Diagnostic and Data Collection Software

Additional Options:

Available Soon: 3 Axis Accelerometer for vibration measurement

Flyspeed GV Installation

- Instrument Dial diameter 3.500" (mm 88,9)
- Dashboard Hole diameter 3.125" (mm 79,4)
- Depth 4.00" (mm 101,6)
- Approximate weight 0.5 lb. (gr 250)

5.7.2 Regulating minimum pitch using the *Flyspeed Gv*

Caution: *Before starting the engine, remove the spinner so as to simplify later adjustments. To ensure safety and reduce incidents choose a location, which is free and clear of objects, obstacles and people. Also, ensure that the area is devoid of gravel, sand and other materials which could be sucked into the path of the propeller potentially damaging it, and/or causing injury to you and others participating in the process.*

- Verify max take-off RPM: with full brakes and chocked wheels, progressively apply full throttle. To avoid potentially going past red-line, we recommend starting with a moderate/high pitch setting. Max take-off RPM should be set, using the *FLY* switch, at approx 50 propeller RPM beneath max take-off RPM as specified in the aircraft operating manual or the engine operating manual.
- Once the correct RPM value is achieved, throttle back gently and switch the engine off. Regulate the three adjustment points surrounding the electric motor by carefully and uniformly sliding them to touch the support within the hub, this sets the physical end-run limits. Then tighten the adjustment points using the three self-blocking lug-nuts, do this carefully while keeping the adjustment points immobile with a Hallen wrench. In case of any doubts regarding the hub installation or the electric pitch control system, we ask that you contact the manufacturer or an authorized technician.

Caution: *If the adjustment points are not properly registered, damage could occur as the rotating asymmetry will result in greater current loads, greater friction of the movable parts, damage to the adjustment points themselves, and differences in pitch between the propeller blades.*

Caution: *The use of variable pitch propellers requires the presence of a Manifold Pressure Gauge. Consult the aircraft-operating manual for maximum RPM and Manifold Pressure combinations. Pay special attention to RPM settings that are permissible only for limited time periods. We recommend using red tape to identify on the RPM gauge directly, RPM settings that are to be avoided for extended periods of time. In addition the RPM gauge must be registered on an annual basis, and the accuracy should be within 50 RPM, consistent inaccuracy is cause to replace or repair the instrument.*

Caution: *In case of any doubts regarding the hub installation or the electric pitch control system, we ask that you contact the manufacturer or an authorized technician.*

Caution: *Never apply direct current to the hub's electric motor. Do so only through a Quinti Avio controller. Do not attempt to modify pitch without the blade being mounted, the end-runs could be damaged. Never use a battery charger to power the control unit, only use professional lab quality, stabilized power units that guarantee constant current output of 12 – 13.8V.*

Caution: *During the first installation and during overhaul, it is possible for a small quantity of grease to leak from the hub onto the spinner and blades; use a mild detergent to remove the grease in such cases. Any grease loss should end within 15 to 20 hours of operation.*

5.7.3 RPM Sensor and Magnet Support Pylon installation

5.7.3.1 Hubs with flange mounted pre-assembled Slip Ring

- Mount the support pylon beneath one of the six bolts fastening the hub set to the engine flange, make sure the magnet is facing the brush mounting bracket. The HALL sensor has a DB9 type plug which plugs into the back of the *Flyspeed GV*, guide the wire through the firewall and bring it to the brush mounting bracket. At this point mount the HALL sensor on the plastic frame and then mount the plastic frame onto the brush mounting bracket.

Caution: *It is essential that you do not pass the *Flyspeed GV* wiring near Magneto wiring or Spark Plug wiring, this is to avoid a potential electrical disturbance which could affect the *Flyspeed GV*'s proper interpretation of engine RPM and consequent incorrect functionality.*

- The magnetic sensor needs to be carefully positioned perpendicular to the magnet for proper reading to occur. The ideal distance between the magnet and the sensor tip is 1 to 3 mm. Set at 1.5 mm. Next, tighten the support pylon with a torque wrench being careful not to move the sensor positioning. Also tighten the plastic support frame using a gripping agent such as Loctite 222. To verify correct magnet positioning, connect *Flyspeed GV* to a 12V power source and then move the propeller manually back and forth so that the magnet passes in front of the sensor. Proper positioning will result in an RPM reading between 100 and 1000 on *Flyspeed GV*'s display.

Caution: *Before manually rotating the propeller ensure that both L & R magnetos are in the OFF position in order to avoid inadvertently starting the engine.*

5.7.3.2 Hubs with the Slip Ring mounted on the propeller gearbox

- The magnet is already in place on the aluminum support on the slip ring. The HALL sensor has a DB9 type plug which plugs into the back of the *Flyspeed GV*, guide the wire through the firewall and bring it to the prop gearbox. Normally the sensor mounting pylon is already assembled and in place. In any case it is still necessary to tighten it using a gripping agent such as Loctite 222.

Caution: *It is essential that you do not pass the Flyspeed GV wiring near Magneto wiring or Spark Plug wiring, this is to avoid a potential electrical disturbance which could affect the Flyspeed GV's proper interpretation of engine RPM and consequent incorrect functionality.*

- The magnetic sensor needs to be carefully positioned above the magnet for proper reading to occur. The ideal distance between the magnet and the sensor tip is 1 to 3 mm. Set at 1.5 mm. Next, tighten the support pylon with a torque wrench being careful not to move the sensor positioning. Also tighten the plastic support frame using a gripping agent such as Loctite 222. To verify correct magnet positioning, connect *Flyspeed GV* to a 12V power source and then move the propeller manually back and forth so that the magnet passes in front of the sensor. Proper positioning will result in an RPM reading between 100 and 1000 on *Flyspeed GV*'s display.

Caution: *Before manually rotating the propeller ensure that both L & R magnetos are in the OFF position in order to avoid inadvertently starting the engine.*

5.7.4 Installing *Flyspeed GV* on the instrument panel

5.7.4.1 General Information

We recommend installing your *Flyspeed GV* near the engine instruments, in a position optimized for pilot visibility and access. Avoid placing it near instruments with high electromagnetic emissions, or improper shielding. Complete all wiring and manifold tube connections before fixing the instrument into place.

5.7.4.2 Technical Specifications

Input	9/16 V
Draw, motor excluded	<0.1A
Motor Current	0.1-15A
RPM	600-20000
Pressure sensor	10-45 inches Hg
Short-circuit protection	2-15 A Polyswitch, check label for installed version

The hub's electric motor is responsible for most of the current draw. *Flyspeed GV* itself only draws approx. 0.1A. Keeping in mind maximum electric motor draw, we recommend installing a 10A breaker, only in case of electrical stop system installed use a 15A breaker.

Caution: *Before Installing Flyspeed GV ensure that the cabling connecting the battery to the engine starter is sufficiently stout. In certain cases, on Rotax engines, during engine start high current draws were observed (approx. 170A at peak) which resulted in a drop of current to the instrument panel master to below the minimum necessary of 9V. In such cases Flyspeed GV goes into 'tilt' and will not operate in a standard manner, or it will enact a complete re-set.*

Flyspeed GV has two separate internal circuits, one for automatic operational mode, and one for emergency mode.

- The automatic constant speed circuit can be used with or without DMP control. Manual mode is also available (non constant speed). This circuit is protected by an internal solid state Polyswitch with automatic reset.
- You can activate the emergency circuit from the instrument panel. The switch can handle currents up to 6A. The circuit includes a resetting breaker (30 second reset interval). When in emergency mode, for best results, manipulate propeller pitch in small increments.

Caution: *In emergency mode the aforementioned protection limits excessive torque to the pitch adjusting mechanism. Ensure that the electric motor is operating in ranges far from the end-runs.*

5.7.4.3 Connecting *Flyspeed GV* to the Hub's electric motor

Keeping in mind that wire length dictates wire thickness in cases of current transmission, we recommend the use of type 16AWG or 1.38mm/2 cross-section wires. To properly connect the wires to the to the brush mounting will require you to:

- Place the *Flyspeed GV* Emergency/Auto switch in the 'Emergency' position.

- The wires connecting the brush mounting must be connected so that acting on the 'UP' arrow will result in blade pitch increase.
- Switch the Emergency/Auto switch back to 'Auto'. Activate 'MANUAL' mode by pressing the 'SEL' key. Press the ▲ ('UP') key and verify blade pitch increase.

Caution: *Different pitch variation between Automatic and Emergency modes is not acceptable.*

5.7.4.4 Connecting the intake manifold pressure tube (DMP)

Employ a 5-6mm fuel tube of the same quality and for the same fuel type used by the engine. Attach the tube to the appropriate connection on the back of the *Flyspeed GV*, and then connect the other end to the intake pressure outlet of the engine. Alternatively connect the tube to a standard MAP instrument using a 'Y' or 'T' connection. Ensure proper fastening at all points in order to avoid accidental disconnections.

5.7.4.5 Initial *Flyspeed GV* power-up

For the first two seconds the screen will display the manufacturer name and product version, then *Flyspeed GV* will enter the PROP CYCLE mode. If you select AUTO PROP CYCLE, the propeller will automatically complete a cycle from maximum to minimum pitch and then settle to preset take-off pitch.

If AUTO PROP CYCLE is not active, the *Flyspeed GV* screen will display MANUAL.

Scrolling through the menu you can choose PRESET or CYCLE PROP. Before starting the engine it will be necessary to select CYCLE PROP and then ENTER to complete the max/min pitch cycle described above.

The PROP CYCLE function will not occur in any case where propeller revolutions exceed the preset value set by NO MOVE RPM. This is to avoid a PROP CYCLE from initiating while in flight should *Flyspeed GV* be inadvertently disconnected from the power supply and immediately reconnected again.

Once the prop has correctly completed the cycle, the *Flyspeed GV* will default to PRESET mode and RPM, TAKE OFF and DMP will be displayed on the screen.

Caution: *It is mandatory to conduct the Flyspeed GV PROP CYCLE sequence with engine off before each flight. The sequence runs a series of internal and system checks. During the max/min cycle, the display will show hub motor electrical draw and the time employed to reach the mechanical end-runs. Both the electrical draw and time values are important indicators of the system's health. A high draw value or unusually long time can be indicative of a potential malfunction within the hub. Flyspeed GV will automatically go to MANUAL mode in the case of the instance described above. Please see Operational Guidelines for additional information.*

5.7.5 Preset Parameters and Customization

Modifying preset parameters should only be attempted once in possession of extreme operational familiarity with *Flyspeed GV* and under the guidance of the manufacturer. *Flyspeed GV* is delivered with preset parameters based on the engine type in use.

In order to manipulate preset parameters, turn on *Flyspeed GV* and immediately press ENTER for two seconds and release. From this point, until shutdown, ACCESS CODE will appear as a menu choice you can reach by scrolling with SEL. Selecting ACCESS CODE with ENTER will allow you to enter one of the codes described below to gain access to the parameters lists.

Scrolling through individual parameters is achieved with the SEL key. Once a parameter is visible on screen, its value can be modified using the ▼▲ (UP/DOWN) keys, keeping in mind that the value change will be effective only after confirming with the ENTER key—at this point the text STORED will confirm your change.

System version 7.1 functionality

MANUAL	Pressing the up/down arrow keys ▼▲ you increase/decrease pitch (not constant speed functionality).
PRE-SET	Confirm with ENTER key. It engages the preset parameter, constant speed, mode.
CYCLE PROP	After power up it check-cycles the prop from Max Pitch to Min Pitch and their respective mechanical stops. Once complete it settles on TAKE OFF mode (pitch setting). See also AUTO PROP CYCLE.
ACCESS CODE	After power up press ENTER for two seconds. INSERT CODE appears. Hit ENTER again and the sequence: ▼▲▼▲
DMP CONTROL	Enable DMP (Differential Manifold Pressure) to manage pitch control. ON = DMP selects pitch based on DMP/RPM (correct use) OFF = RPM is controlled by: ▼▲ keys <u>(do not use on OFF!!)</u>
AUTO PROP CYCLE	If ON, prop cycle sequence (CYCLE PROP) is executed automatically. If OFF, CYCLE PROP needs to be executed manually, by selecting with SEL and confirming with ENTER
T-OFF TIME LIMIT	If ON, maintains TAKE OFF RPM for number of seconds specified in MAX TAKE OFF TIME. At timeframe end, it enters CLIMB mode automatically precluding the possibility to revert to take off mode. If OFF, take off mode can be re-engaged.
PROP PITCH DOWN	OFF = ▲ will increase pitch “reverse engine rotation” ON = ▲ will increase pitch “software direction control” ALWAYS USE IN OFF MODE.
HIGH PERFORMANCE	ON = For special hubs with fast pitch variation control OFF= in all other cases
EXTENDED PITCH	ON = For hubs compatible with Full Feathering and/or reverse OFF= in all other cases

F_FEATH/REVERSE	Active only with EXTENDED PITCH set ON ON = reverse OFF = full feathering	
MAX PROP RPM FC	Defines RPM value above which no pitch control will occur	
NO MOVE RPM	Defines RPM value beneath which PROP CYCLE can occur, before full feathering or reverse can take place or High Performance mode can initiate on special hubs.	
T-OFF RPM	Defines RPM for:	take-off
CLIMB RPM	“	climb
CRUISE_7 RPM	“	fast cruise
.....		
CRUISE_0 RPM	“	slow cruise
EC. CRUISE RPM	“	economy cruise
LAND RPM	“	landing pattern
T-OFF DMP	Defines minimum DMP for:take-off	
CLIMB DMP	“	climb
CRUISE_7 DMP	“	fast cruise
.....		
CRUISE_0 DMP	“	slow cruise
ECONCRUISE DMP	“	economy cruise
LAND DMP	“	landing pattern
	Beneath this DMP value further automatic pitch control is not possible while DMP CONTROL is ON.	
COARSE PULSE DUR	defines the duration of electric motor impulse insistence in case RPM error margin exceeds that defined by COARSE HYST RPM	
COARSE PULSE DLY	defines the time interval (delay) between two consecutive COARSE PULSE DUR impulses	
COARSE HYST RPM	defines error margin for electric motor management during broad RPM control events	

FINE PULSE DUR	defines the duration of electric motor impulse insistence in case RPM error margin exceeds that defined by FINE HYST RPM
FINE PAUSE DLY	defines the time interval (delay) between two consecutive FINE PULSE DUR impulses
FINE HYST RPM	defines error margin for electric motor management during precise RPM control events
ENG PROP RATIO	RPM/propeller RPM ratio based on PSRU ratio if applicable
T-OFF PITCH %	take-off pitch setting
LANDING PITCH %	landing pitch setting
MAX DMP RATE	DMP rate change; when it is exceeded pitch increase will occur for the number of seconds as specified in LONG PITCH INCR. Only on special High performance hubs.
LONG PITCH INCR	see MAX DMP RATE
MAX T-OFF TIME	defines time in seconds after which TAKE OFF RPM transitions to CLIMB RPM
MIN PROP CYCLE	minimum time to perform CYCLE PROP
MAX PROP CYCLE	maximum time to perform CYCLE PROP
DMP OFFSET	pre-set to 30.0 inches
DMP GAIN	DMP sensibility adjustment (calibration)
DMP WINDOW	defines control window for DMP sensibility
MAX CYCLE CURRENT	defines maximum electric current use during CYCLE PROP
MAX MOT CURRENT	defines maximum electric current used in constant speed mode
MED MOT CURRENT	defines maximum electric current used in manual mode. Also when using special hubs in full feathering, reverse and High Performance modes.
MIN MOT CURRENT	defines minimum electrical current for the hub motor
HI CURRENT DLY	defines time delay in reading electrical current values (0.05, equal to 50 milliseconds)
SHUNT RESISTOR	defines the unit's resistance thresholds. Current model is 0.10 ohm. Check the label for additional info. 2000 and 2001 models: LC = 0.22 ohm, HC = 0.03 ohm

PROP TEST CYCLE	automatic propeller self-test. Only for use during in-shop maintenance. It should be off during normal flight operations.
BASIC MODE	constant speed functionality disabled. Pitch control can be achieved only through manual intervention. This function displays the electrical current value and its direction while overload protected.
FACTORY PRESETS	manufacturer's preset parameters. Select tables to modify using ENTER. Cycle <i>Flyspeed GV</i> off, then on in order change parameter values.

TABLES:

Table 0	reserved The user can add/change data keeping count of engine characteristics and propeller use.
Table 1	Rotax 912 80 HP
Table 2	Rotax 912S 100HP
Table 3	Rotax 914 Turbo
Table 4	Midwest Rotare 105 HP
Table 5	Alfa Romeo avionic conversion
Table 6	Continental C85 (non-gearboxed)
Table 7	Lycoming
Table 8	Subaru 1.82 gearbox

Tuning intake pressure differential readings: *Flyspeed GV* is delivered already tuned, complete tuning guidelines can be found however, in the service manual.

5.8 Operational Guidelines

5.8.1 General concepts for *Flyspeed GV* use with standard hubs and DMP control

- Take-off maximum power is delivered to the propeller while not exceeding the time allowed at the full power setting. With speed increase, there is a corresponding load decrease on the propeller, creating a condition where applied full power could lead to excessive RPM as defined by the engine manufacturer. *Flyspeed GV* will automatically increase blade pitch, maintaining constant speed, and avoiding 'red-lining' or 'overspeed'.
- Once you reach a safe altitude, power must be throttled back to the maximum continuous setting as defined by the manufacturer. *Flyspeed GV* will automatically transition to CLIMB mode based on pre-programmed parameters where the minimum DMP value for CLIMB will correspond to maximum continuous power. The automatic transition to CLIMB occurs after the number of seconds as specified by MAX TAKE OFF TIME. If MAX TAKE OFF TIME is OFF the reduction in power setting must occur by throttling back and bringing the DMP value beneath the minimum required by TAKE OFF RPM. Current DMP value is constantly visible on the display screen.
- At cruise altitude any of the many *Flyspeed GV* cruise settings can be engaged through throttle action. There are nine cruise settings: CRUISE_7 to CRUISE_0 and ECONOMY CRUISE for maximum fuel efficiency. If fewer than nine cruise settings are preferable, they can be reconfigured and reduced through parameter customization. If you choose to do so, be careful to maintain a linear progression through the range of settings you define.
- While descending, or preparing to land, blade pitch must revert to an angle close to that used for take-off. LAND mode achieves that. It is engaged by the combination of RPM and DMP values requiring a reduced pitch setting. Further reduction in power (beneath the minimum DMP setting for LAND) will result in IDLE mode and blade pitch will remain fixed (no longer constant speed). Adding power however, will re-initiate automatic selection of the appropriate mode, from CLIMB to LAND, without the necessity of Pilot interaction with *Flyspeed GV*.
- An alternative landing approach is as follows. Reduce power until the *Flyspeed GV* displays IDLE. Press ENTER (below NO MOVE RPM and minimum DMP value) *Flyspeed GV* will select the correct blade pitch specified by LANDING PITCH%. This will allow the application of full power for take-off. If LANDINGPITCH% is not defined, *Flyspeed GV* can achieve the proper pitch by returning to the minimum allowed. When this is occurring MOV_LA is displayed and when the transition is complete TAKE OFF will be displayed confirming that the desired pitch setting has been attained. During this relatively short timeframe, it is important to be careful not to exceed RPM allowances. The pitch angle attained in this manner will be slightly higher than that attained on the ground prior to take-off, the reason being that the motion through the air 'lightens' the load on the blades slightly compared to when the aircraft is stationary on the ground.
- *Flyspeed GV* during all operational activity, constantly monitors the pitch variation mechanisms to ensure that it is functioning properly and efficiently. This is achieved by constantly checking the electric current levels. High current levels might indicate abnormal mechanical friction. Low current levels indicate an electrical anomaly or an increase in resistance at the slip ring or at the brushes.

5.8.2 General concepts for *Flyspeed GV* use with special hubs and DMP control

1) Selecting Full Feathering

This option may be used when the propeller is turning at a speed below NO MOVE RPM and IDLE appears on the display. To engage press ▼, FULL-FT<> will appear. Shut the engine off and press ENTER, the propeller will move to **full coarse** and display MANUAL when it is achieved, *Flyspeed GV* must remain on. Before restarting the engine you must press ▼▲ simultaneously and release. The prop will transit to LANDING PITCH % and *Flyspeed GV* will display T_OFF, at this point the engine can be restarted. Normal flight can resume in one of two ways:

1. Initiate a gentle climb as if in TAKE OFF adding power gently to avoid an 'overspeed' event.
2. Press SEL until PRE_SET is displayed, then confirm with ENTER. Constant speed logic will be resumed according to DMP governance.

Caution: Use this functionality exclusively with hubs/prop sets predisposed for full feathering functionality.

Caution: This option should be employed only at a sufficient altitude to guarantee a safe power-off landing in case of failure to restart the engine.

Caution: *Flyspeed GV* and full feathering necessitate HIGH PERFORMANCE to be switched OFF. Also the LANDING PITCH % parameter value must be greater than the TAKE OFF PITCH % parameter value, this is to avoid the possibility of an 'overspeed' as power is re-applied.

2) Selecting Reverse

This option may be used when the propeller is turning at a speed below NO MOVE RPM and IDLE appears on the display. Pressing ▼ will make REVERSE<> available as an option. Selecting ENTER will initiate the propeller's transition to **full fine** (which corresponds to reverse) and *Flyspeed GV* will enter MANUAL mode. At this point manipulate pitch as necessary with the ▼▲ keys.

To exit REVERSE mode scroll with SEL and select PRE-SE with ENTER. You will enter IDLE mode, now press and release ▼▲ simultaneously. LANDING PITCH % will be achieved and the display will show T_OFF. Allowing you to reapply power as necessary.

Caution: Always use minimum power settings to avoid 'redlining'.

Caution: This functionality is to be employed exclusively with hub/prop sets specifically designed and tested for reverse use.

Caution: Reverse functionality is for exclusive use with hydroplanes or amphibious aircraft after a water landing for taxiing purposes.

Caution: *Flyspeed GV* and reverse necessitate HIGH PERFORMANCE to be switched OFF. Also the LANDING PITCH % parameter value must be equal to the TAKE OFF PITCH % parameter value, this will allow take-off to be performed once the ▼▲ keys have been simultaneously engaged and released.

Caution: A water landing must be executed in automatic mode without confirm landing intention with ENTER. Doing so would bring create a situation of likely 'overspeed' as the LANDING PITCH % and TAKE OFF % values are equal in REVERSE mode

3) High performance

This mode should be used in high performance aircraft in which the propeller can serve as a braking device upon landing. In standard operational mode 'redlining' becomes a real possibility in case power needs to be reapplied quickly. In such cases the sudden DMP increase (in excess of MAX DMP RATE) will initiate rapid, within mechanical limits, transition from the very low landing pitch angle to a broader pitch angle suitable for reapplying power. The preset value for this pitch angle transition is determined by LONG PITCH INCREMENT. Subsequent to which normal take-off mode will be employed.

This option may be used when the propeller is turning at a speed below NO MOVE RPM and IDLE appears on the display. Selecting ENTER will initiate the propeller's transition to LANDING PITCH % while the *Flyspeed GV* will display MOV_LA; once the correct pitch is attained T_OFF will be displayed and landing or go-around are both options. In case of a landing, it will be necessary to perform PROP CYCLE.

Caution: Do not preset LANDING PITCH % value much lower than TAKE OFF PITCH % value, despite the hub's rapid pitch change rate, it may not be able to transit the pitch angle quickly enough to disallow an 'overspeed' in the case of full power re-application.

Caution: Employ this operational mode only at safe approach altitudes as the braking effect it generates can quickly slow the aircraft to near stall speed. As a consequence of the braking effect, a steeper glide path will be required.

Caution: This functionality is to be employed exclusively with hub/prop sets specifically designed and tested for high performance use.

SAFETY CONSIDERATIONS

- In order to avoid engine damage, never exceed allowed RPM.
- *Flyspeed GV* manages maximum power on take-off while avoiding RPM 'overspeed'.
- An electrical malfunction could potentially 'freeze' the propeller at a high or low pitch setting. In this event the engine may not be able generate sufficient power for take off or climb.
- In the event of severe turbulence it may be difficult to manage the *Flyspeed GV* control keys, as it may be difficult to operate in an efficient constant speed manner. In such cases we recommended employing MANUAL mode.

Caution: While in flight and with the reverse hub type, **NEVER** press the ▼ ▲ keys simultaneously. The subsequent pitch transition to Full Fine could slow the aircraft dramatically and create the conditions of imminent stall.

5.8.3 OPERATIONAL GUIDELINES

TAKE-OFF

- 1) Initiate CYCLE PROP with engine off in order to reach minimum pitch setting. If AUTO PROP CYCLE is ON, this event will occur after start up. During the pitch cycling, the *Flyspeed GV* display will show current level and time, and at the completion of the cycle will display T_OFF. If an error occurs it will default to MANUAL mode.
- 2) Start the engine for warm-up, taxi, and take-off.
- 3) Apply full power and when max RPM are reached release the brakes.
- 4) After take-off, CLIMB mode will automatically be engaged. Adjust throttle position for optimal DMP setting. If DMP CONTROL is ON, *Flyspeed GV* will automatically optimise RPM according to DMP as established through throttle position.

Take off from high altitude fields while in Automatic Pitch Control

If taking off from a higher altitude field than normal, it is recommended that you employ a different procedure than normal after the PROP CYCLE sequence has been completed. This is to avoid a potential 'overspeed' event which could occur due to the lower air density found at higher elevations.

1. Execute a normal PROP CYCLE sequence
2. Start the engine
3. Enter MANUAL mode through the SEL key
4. Re-enter PRE_SET mode through SEL key and ENTER to confirm
5. At this point, DMP control will take over RPM management. Max allowable RPM will be a determined by the CLIMB parameter.

Caution: *This procedure will avoid an 'overspeed' event. The pilot must recognize that max RPM will be lower than normal, and less quickly attained. This is important to determining the safety of the take-off maneuver.*

Take off from high altitude fields while in Manual Pitch Control

If taking off from a higher altitude field than normal, it is recommended that you employ a different procedure than normal after the PROP CYCLE sequence has been completed. This is to avoid a potential 'overspeed' event which could occur due to the lower air density found at higher elevations.

1. Execute a normal PROP CYCLE sequence
2. Start the engine
3. Enter MANUAL mode through the SEL key
4. Increase blade pitch sufficiently to avoid an 'overspeed'
5. At a safe altitude re-enter PRE_SET mode through SEL key and ENTER to confirm.
6. At this point, DMP control will take over RPM management.

Caution: *When in MANUAL mode, because of the lower wind resistance after rotation, RPM will tend to increase. The pilot must consider this tendency and take the appropriate steps to avoid an 'overspeed' event during this initial phase of flight.*

CRUISE

With DMP CONTROL ON , and flying at high altitude or in non-standard temperature/humidity conditions, the preset RPM/DMP settings may require some intervention as MAP will deviate substantially from DMP because of the lower atmospheric pressure. Use the ▼▲ keys for the following effect:

DMP Setting	Standard RPM	Down once	Up once	Up twice
T_OFF	5800	5800	5500	5400
CLIMB	5500	5800	5400	5300
CRUISE_7	5400	5500	5300	5200
CRUISE_6	5300	5400	5200	5100
CRUISE_5	5200	5300	5100	4900
CRUISE_4	5100	5200	4900	4700
CRUISE_3	4900	5100	4700	4500
CRUISE_2	4700	4900	4500	4300
CRUISE_1	4500	4700	4300	4100
CRUISE_0	4300	4500	4100	3800
ECON_CRUISE	4100	4300	3800	3800
LAND	3800	4100	3800	3800

If you have significantly deviated from standard pre-set (PRESET) functionality and chose to re-engage it a new, press SEL bottom, when in PRESET press ENTER bottom. Pitch control will revert to standard DMP control

LANDING

- 1) With DMP CONTROL enabled, reduce power until LAND is displayed, the correct descent/landing pitch will automatically be selected.
- 2) If additional power reduction is necessary, *Flyspeed GV* will 'freeze' blade pitch and display IDLE. Transitioning from LAND to IDLE or IDLE to LAND is automatic. Applying full power for a go-around will not 'redline' however as *Flyspeed GV* will achieve maximum continuous RPM (with TAKE OFF TIME set ON) or maximum RPM (with TAKE OFF LIMIT set OFF).
- 3) You can achieve reduced pitch for landing in another manner as well; to confirm landing intention while the prop is spinning beneath NO MOVE RPM and *Flyspeed GV* displays IDLE, select ENTER. Pitch will transition to LANDING PITCH % and MOV_LA will be displayed, when proper pitch angle is achieved *Flyspeed GV* will display T_OFF and will be ready for landing or go-around. In the case of landing, it will be necessary to execute a PROP CYCLE before take-off.
- 4) TO land with DMP CONTROL set to OFF, reduce power and select LAND manually on *Flyspeed GV*, landing pitch will be imposed.

Following are possible manual settings:

- a) After PROP CYCLE pitch angle is determined by the TAKE OFF PITCH % parameter value.
- b) Selecting IDLE and ENTER will determine pitch angle in accordance with LANDING PITCH % parameter value.

- c) Simultaneously pressing the ▼ ▲ keys will result in LANDING PITCH % parameter value. (Please check for operational modality based on hub type).
- d) Selecting IDLE and will 'freeze' pitch angle.

5.8.4 Configuration setting and details

Flyspeed GV can manage multiple modes: **full feathering, reverse, high performance,** as well as standard.

- a) **Standard Hub:** Cannot be employed in Full Feathering, Reverse, or High Performance modes because of standard pitch angle change velocity.
- b) **Full Feathering Hub:** Cannot simultaneously handle Reverse and High Performance modes.
- c) **Reverse Hub:** Cannot simultaneously handle Full Feathering and High Performance modes.
- d) **High Performance hub:** Cannot simultaneously handle reverse e full-feathering

5.8.5 Trouble shooting

- 1) If the RPM display shows “-----“ *Flyspeed GV* is not receiving RPM data. This may be an issue of extremely low RPM or of sensor non-connectivity.
Check the following:
 - a) Check all *Flyspeed GV* connections
 - b) Verify magnet/sensor proximity and magnet polarity
 - c) Ensure secure magnet sensor fastening
 - d) Damaged or inoperable magnet sensor
 > If the problem persists contact an authorized service provider or the manufacturer.
- 2) No DMP variation with different throttle settings:
 - a) Disconnect *Flyspeed GV* pressure-sensing tube from engine placement. Blow into tube lightly, *Flyspeed GV* should register and display a 5”-10” pressure increase.
 - b) Verify that the tubes connected to the carburetors for MAP reading are intact and that all seals are tight, so as to rule out the possibility of air leaks.
 > If the problem persists contact an authorized service provider or the manufacturer.
- 3) Hub motor is inactive
 - a) Verify proper *Flyspeed GV* display function and no error-messaging.
 - b) Set *Flyspeed GV* to EMERGENCY mode and connect DVM (Digital Voltmeter) through the slip ring. Move selector switch UP and DOWN and verify +12 and -12 Volts. With voltage reaching the slip ring, ensure motor functionality. In voltage absence check all components for functionality including wiring, brushes, brush mountings etc.
 - c) The LED will illuminate when the hub motor is turning. If that is not occurring be sure the AUTO/EMERGENCY switch is not set to EMERG and that there is not an issue of excess current draw.
 - d) See error message. Footnote 2.
 > If the *Flyspeed GV* 's display is operating normally, but voltage is still abnormal contact an authorized service provider or the manufacturer. Opening the instrument casing will void warranty coverage.

5.8.6 Preventive maintenance

Regularly inspect the brushes and the slip ring. Dirty contact patches can be cause of electrical 'arcing' which will reduce component service life and can cause static noise within the aircraft and may eventually damage *Flyspeed GV*.

We recommend periodic wiring inspections, be looking for cracked/frayed wires, loose connections and severe bends/folds.

Also look for leaks, crimps, cracks and any other damage, due to aging and wear, to the tubes collecting intake manifold pressure data.

5.8.8 Error messages

1. SHORT CYCLE ERR - The time employed to cycle the propeller was under MIN CYCLE TIME. This can mean that the hub motor required an excess of current, or that MAX CYCLE CURRENT is set too low. Inspect the hub/prop for any mechanical obstructions anomalies.
2. LONG CYCLE ERR - The time employed to cycle the propeller was over MAX CYCLE TIME. This can mean that the hub motor required less current than normal, or that MAX CYCLE CURRENT is set too high. Check that the AUTO/EMERGENCY switch is set to AUTO and that the LED is illuminating. An open circuit somewhere between the *Flyspeed GV* and the engine can cause this, or the unit may be malfunctioning. See footnote 3 under DOUBT RESOLUTION.
3. PROP UNDER CURR - The hub motor is drawing less current as set by MIN MOT CURR. See footnote 3 under DOUBT RESOLUTION.
4. PROP OVER CURR - The hub motor is drawing more current as set by MIN MOT CURR. The motor is absorbing excess amperage. Likely causes are increased mechanical resistance (due to damage or dirt) or a damaged electric motor .
5. INVALID PRESET - The selected value is outside of the range of available choices. Review the manual for acceptable values or contact the manufacturer or dealer.
6. NOT PRESET LOADED - *Flyspeed GV* has not yet been pre-configured for use. See INVALID PRESET above.

6.0 Emergency procedures

Following are potential malfunction sequences which could adversely affect the propeller/hub system's operation.

6.1 Manual *FLY* Pitch Control

In the case that the *FLY* manual control is not enacting pitch change, it is imperative to determine whether the flight can be safely continued with the pitch angle currently set. It is recommended however, that you land as soon as possible, to avoid the possibility of entering into unsafe flying conditions. If the pitch angle is set to 'fine' (low pitch) exercise caution in order to avoid 'redlining'. If the pitch angle is extremely high and developing sufficient power to maintain safe flight is difficult, it will become necessary to prepare for an emergency landing.

A

6.2 *Flyspeed Gv* 7.1

The following symptoms of incorrect functionality must be addressed immediately:

- Steep Engine and Propeller RPM variation, especially when sudden, and not co relational to correct pitch control functionality. Not to be mistaken for the normal RPM changes that occur when in DMP CONTROL, between one parameter setting and another, and which can be easily stabilized by 'tweaking' the throttle setting up or down which clears us from the transitional parameter setting determined by DMP WINDOW (usually pre-set with range of 0.4 inch DMP).
- The *Flyspeed Gv* display no longer gives any indications.

In this case, and in all other cases where pitch control is lost due to *Flyspeed Gv* malfunction, the following steps should be taken:

- Throttle back if engine speed is high and an 'overspeed' event may be imminent.
- Select EMERGENCY mode with the appropriate switch and modify pitch as necessary using the switch on the left. Use short pitch movement inputs to maximize accuracy.

Caution: *A long input on the pitch control switch while in EMERGENCY mode can quickly attain a pitch setting which may be in excess of that which was intended. A long input could also trip the resettable switch, designed to protect the EMERGENCY circuitry, which will then make further pitch settings unavailable until it has reset, approximately 20-30 seconds.*

Caution: *If the EMERGENCY mode cannot be called up, blade pitch will remain on the most recent setting. If the pitch setting is in the range of normal flight, you may proceed with caution. Throttle input should be applied as if employing a fixed-pitch propeller.*

Caution: *The pilot must verify low-speed performance on the current pitch setting before initiating landing maneuvers. This in order to know what behavior to expect in the case a go-around becomes necessary.*

Caution: *In the event that the blade pitch is 'frozen' at an extremely high or low setting and performance is affected negatively to the point that it is not safe to continue flying, it is imperative to land immediately. In these cases the engine should be stopped at soon as possible to ensure better glide performance.*

7.0 Inspections, Maintenance, Repairs (LOG BOOK: download from web site)

7.1 Inspections and Maintenance

When environmental conditions are characterized by high humidity levels, exposure to corrosive or acidic substances, the owner/operator must protect the external parts of the hub with an anti-corrosive agent such as CRC.

Regularly scheduled maintenance consists of the following:

- **BEFORE EVERY FLIGHT:** Check the brushes, their mountings, and the slip ring for wear or damage. Also verify that the brushes are positioned correctly. Visually inspect all bolts, nuts, and screws. Inspect the spinner and spinner plate. Note any grease leaks. Check for excessive prop blade 'play' (up to 2° pitch play allowed, no axial or radial play is allowed) . Check all wiring for damage, wear or loose connections. Verify electric motor functionality and blade pitch change on the ground, engine off. Visually inspect each prop blade, check for cracks, dings, and any other damage. Pay particular attention to the root area.
- **EVERY 10 HOURS:** Remove the spinner and check for cracks, corrosion, excess wear, damage, verify that all the seals are intact and that the paint markers for on the bolt/nut connections are correct. Also perform the before every flight check.
- **ONLY AFTER THE FIRST 25 HOURS:** Grease the bearing sets of the blades, the central screw and the bronze scroll and key. Perform the 10 hour check.
- **ONLY AFTER THE FIRST 50 HOURS:** Grease the bearing sets of the blades, the central screw and the bronze scroll and key. Perform the 10 hour check.
- **EVERY 100 HOURS:** Grease the bearing sets of the blades, the central screw and the bronze scroll and key. In case of salt-air conditions or of high temperature variations increase this interval to every 50 hours or three months, whichever comes first. Using a torque-wrench verify the proper setting of the six bolts connecting the hub set to the engine mount, also check the aluminum blade sleeves. Perform the 10 hour check.
- **EVERY 335 HOURS:** Replace the brushes and brush mountings.
- **AT 500 HOURS:** Remove the blades and disassemble their mountings, carefully clean all parts with a mild detergent. Grease everything a new as at 100 hours, repeat 10 hour and pre-flight checks.
- **AT 1000 HOURS:** Complete overhaul to be performed by the manufacturer. Overhaul intervals are specified by operational hours and calendar time in months since manufacture. An overhaul must be performed after a maximum of 72 months from installation, if no more than 24 months have passed since manufacture/overhaul when properly stored. This means that the calendar time TBO (Time Before Overhaul) can be a maximum of 96 months.

Caution: *In case of an 'overspeed' event up to 110% of maximum engine RPM, a 100 hour inspection will be necessary. Between 111% and 120% a manufacturer overhaul will be required. In the case greater than 120% further propeller use is not allowable. Consistent 'overspeed' events can result in structural damage to the propeller which are extremely dangerous.*

7.2 Repairs

All internal hub components are coated with a special protective lubricant when assembled. It is recommended that you protect hub components using diluted motor oil or other corrosion inhibitor. Spinner and spinner plate repairs are not allowed, when damaged, those components must be replaced. In the case of electrical system malfunction, components must be replaced as they cannot be repaired.

Repairs must be performed at an authorized service center and/or by authorized service personnel, all components will be shipped at the owner's expense. Repairs required by damage resulting from accident or misuse are not covered by warranty coverage; repair of damages resulting from accident or misuse are to be performed exclusively by Quinti Avio srl.

Quinti Avio srl should be notified in every case of accident or inoperability diagnosed through inspection or maintenance. The manufacturer or dealer will recommend repair procedures or, if necessary, that the damaged components be returned for factory repair.

8.0 Shipping and Storing

If the propeller needs to be stored for an extended period of time, use the original packaging or similar. Store only at temperatures between -20°C and 35°C Centigrade, and 10% and 75% relative humidity. Avoid high humidity, extreme temperatures, and rapid temperature changes. All metal components need to be coated with an anti-corrosion substance which can be easily removed. Most lubricants will be acceptable provided they do not damage other parts. If the components will travel by sea or be stored near the sea (salt air, fog), all metal parts should be coated with a thick layer of light-grade motor oil.

9.0 - Special tools and materials

With the hub kit is supplied two special keys to use for maintenance:

- Key for # 3 in spare parts manual
- Key for part # 24 in spare parts manual

We suggest to use LOCTITE 222 for light lock, LOCTITE 243 for medium lock, LOCTITE 262 for strong lock.

About greasing operation for Hub maintenance we suggest to use:

- NICO GREASE GN 22 (G-395)
- KLUBER GREASE ISOFLEX LDS 18 SPECIAL A
- AEROSHELL GREASE 22
- MOBILGREASE 28

10.0 Electrical flyspeed diagrams

FLYSPEED GV INSTALLATION rev 2.1 Febr_2002

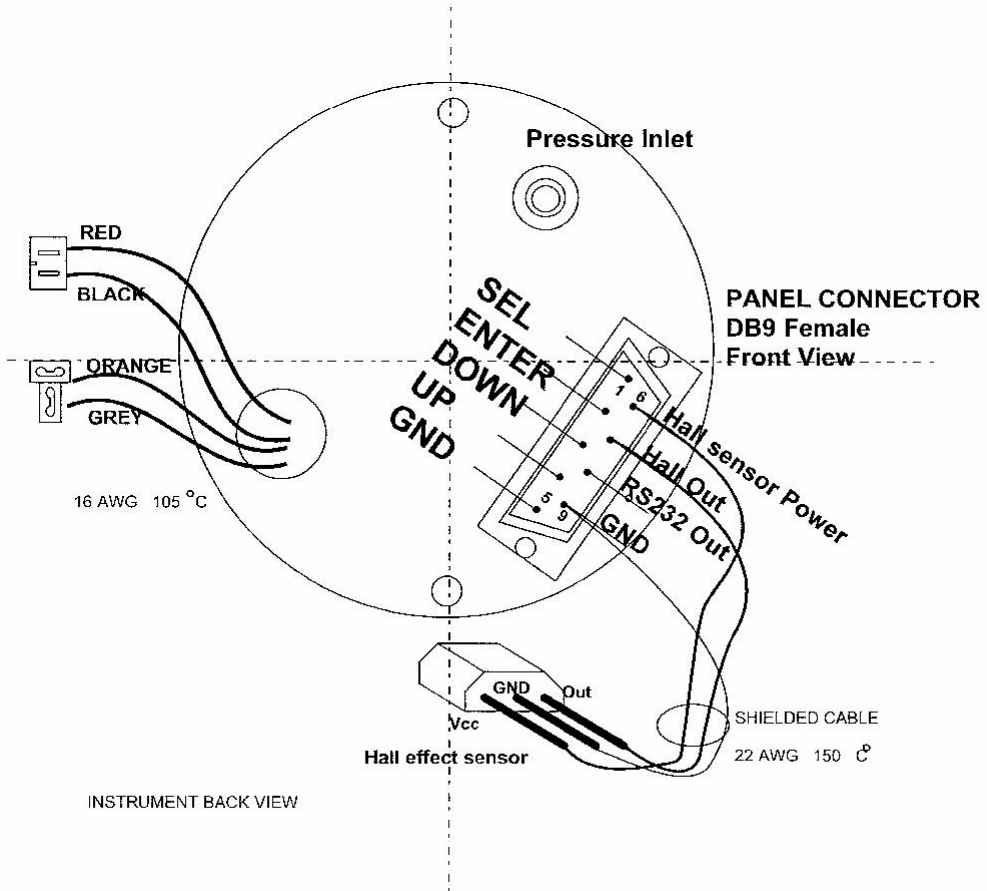
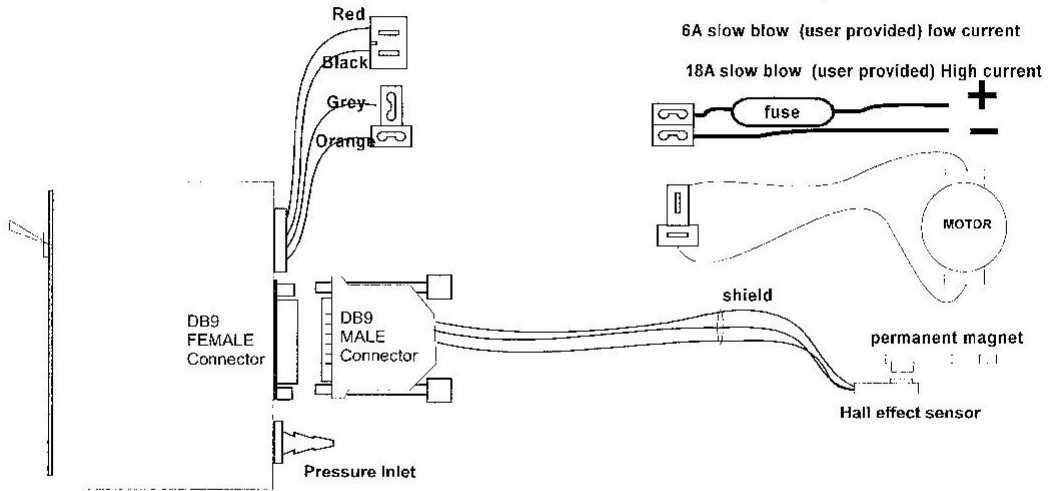

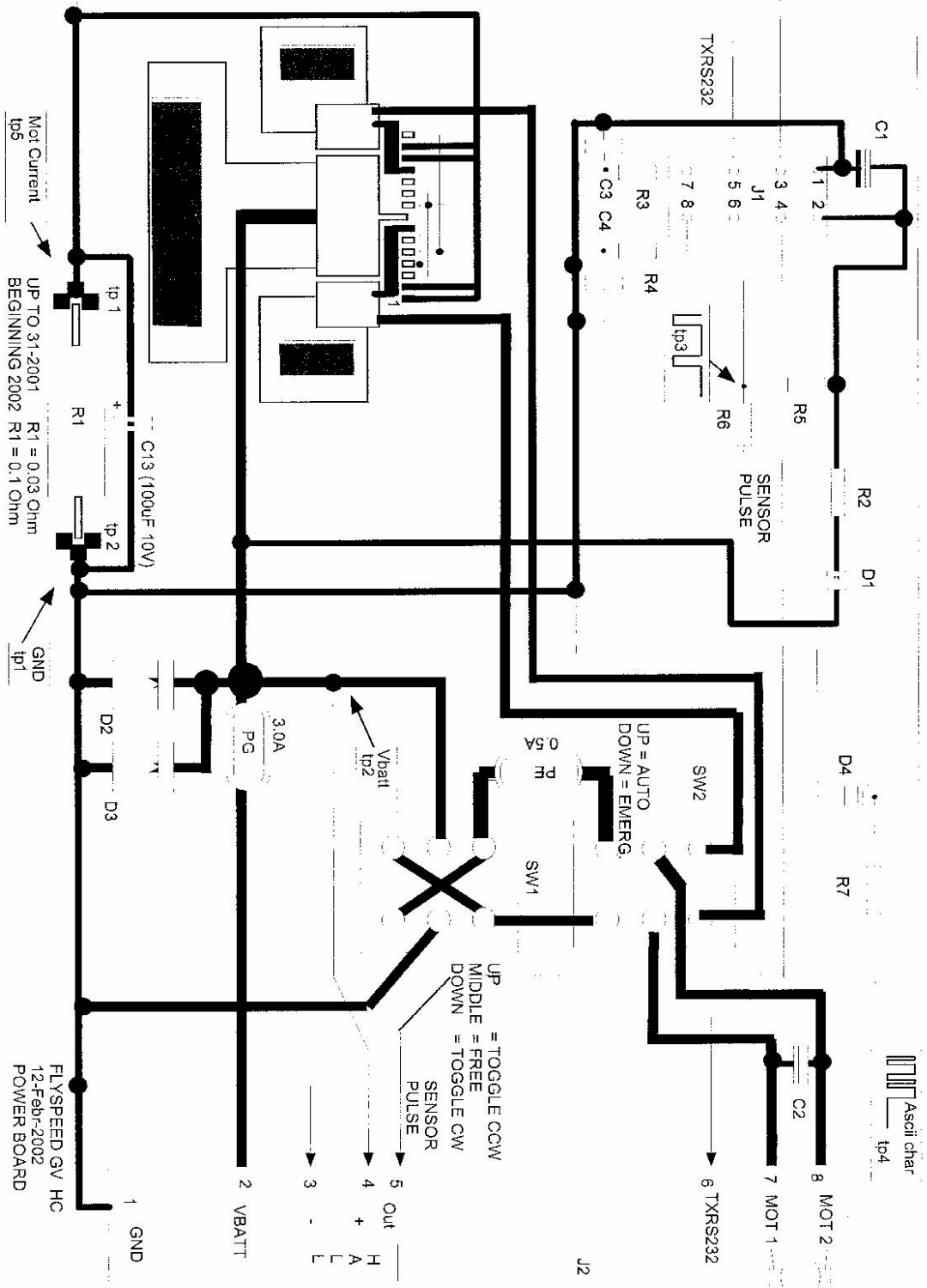

FLYSPEED HC POWER BOARD

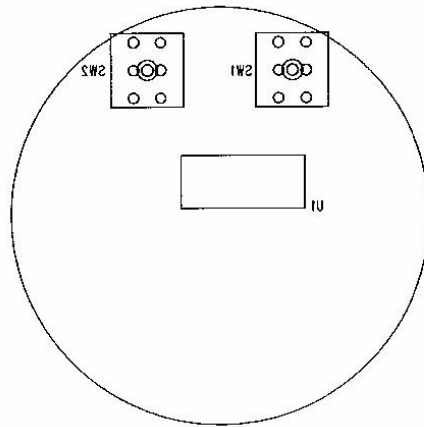

SIDE A

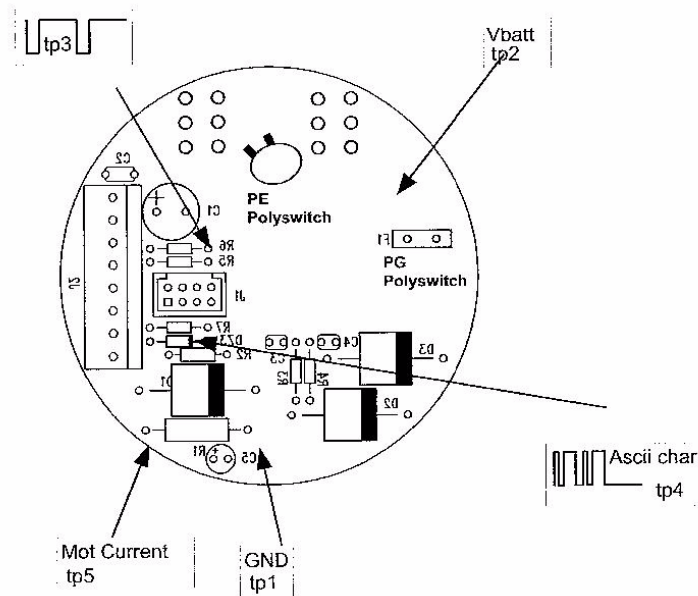

SIDE B

12-Feb-2002
Rev. 2.0

11.0 Spare parts manual

Po	Codice/ Code/ Code/ Kennziffer	Denominazione	Denomination	Dénomination	Bezeichnung	Qt.
1	FD02507001	CANOTTO PORTAPALA	SUPPORT	SUPPORT	TRÄGER	3
2	MC07015002	O-RING mm 55	O-RING mm 55	O-RING mm 55	O-RING mm 55	3
3	FD02727002	GHIERA DI SERRAGGIO 2003	STOP RING NUT 2003	BAGUE ARRET 2003	BLOCKIERGRIFF 2003	3
4	MC07005001	GRANO M5X6 INOX	SOCKET SET SCREW	VIS SANS TETE	GEWINDESTIFT	3
5	MC06035001	CUSCINETTO	BALL BEARING	ROULEMENT	KUGELLAGER	6
6	FD02507003	GUSCIO DI CONTENIMENTO	SUPPORT	SUPPORT	TRÄGER	3
7	FD01343002	CHIAVETTA	KEY	CLAVETTE	PASSFEDER	3
8	FD04433002	BOCCOLA	BUSHING	BAGUE	BUCHSE	3
9	FD00307012 Modifica centraggio	MOZZO TRIPALA ROTAX 2003	FLANGE SUPPORT ROTAX 2003	SUPPORT A FLASQUE ROTAX 2003	FLANSCH ROTAX 2003	1
11	FD02753001	GHIERA BLOCC. INOX	ADJUSTING NUT INOX	EMBOUT INOX	EINSTELLMUTTER INOX	1
12	FD06157003	SUPP. CHIOCC. NEW	SCROLL SUPPORT NEW	SUPPORT VIS MERE NEW	GABELKLEMMSTÜCK NEW	1
13	FD04543004	CHIOCCIOLA TRIP. PASSO 2 NEW	SCROLL 2 NEW	VIS MERE 2 NEW	MITNEHMERBUCHSE 2 NEW	1
14	MC02000015	VITE M4x16 DIN912 INOX	SCREW M4x16 DIN912	VIS M4x16 DIN912	SCHRAUBE M4x16 DIN912	3
15	FD00257002	VITE PASSO 2 NEW	SCREW 2 NEW	VIS 2 NEW	SCHRAUBE 2 NEW	1
16	MC06040001	CUSCINETTO	BALL BEARING	ROULEMENT	KUGELLAGER	1
17	MC02000003	VITE M3X10 DIN912 INOX	SCREW M3X10 DIN912 INOX	VIS M3X10 DIN912 INOX	SCHRAUBE M3X10 DIN912 INOX	4
18	FD02127002	SUPPORTO 2003	SUPPORT 2003	SUPPORT 2003	TRÄGER 2003	1
19	EC15000004	MOTORE HP 11342642	MOTOR HP	MOTEUR HP	MOTOR HP	1
20	FD06127001	GUSCIO DI RINFORZO	SUPPORT	SUPPORT	TRÄGER	1
23	MC06040002	CUSCINETTO	BALL BEARING	ROULEMENT	KUGELLAGER	1
24	FD02123001	TAPPO CARICO VITE	ADJUSTING NUT	EMBOUT	EINSTELLMUTTER	1
25	MC02000007	VITE M6X25 DIN912 INOX	SCREW M6x25 DIN912	VIS M6x25 DIN912	SCHRAUBE M6x25 DIN912	3
26	FD06223003	SUPPORTO ALBERO MIDWEST	SUPPORT MIDWEST	SUPPORT MIDWEST	TRÄGER MIDWEST	1
28	FD40053001	ALBERO SUPPORTO	SHAFT	ARBRE	BOLZEN	1
29	FD05263001	RONDELLE	WASHER	RONDELLE	SCHEIBE	6
30	FD04463001	BOCCOLA	BUSHING	BAGUE	BUCHSE	2
31	FD01638001	PORTASPAZZOLA	BRUSH HOLDER	PORTE-BROSSE	BÜRSTENHALTER	2
32	MC22000001	SPAZZOLE	BRUSH	BROSSE	BÜRSTE	4
33	MC02000013	SEEGER 10DIN492	LOCK RING 10DIN492	ANNEAU ELASTIQUE 10DIN492	SEEGERRING 10DIN492	1
34	MC02000051	TSEI M6X20 INOX	SCREW M6X20 INOX	VIS M6X20 INOX	SCHRAUBE M6X20 INOX	1
35	FD07223006	LAMIERINO BLOCCAGGIO 2003	PLATE 2003	PLAQUE 2003	PLATTE 2003	3
36	MC02000018	VITE M4X10 DIN912 INOX	SCREW M4X10 DIN912 INOX	VIS M4X10 DIN912 INOX	SCHRAUBE M4X10 DIN912 INOX	2
37	FD02707002	GHIERA DI FISSAGGIO	STOP RING NUT	BAGUE ARRET	BLOCKIERGRIFF	3
38	MC02000011	PALA	BLADE	PALE	-	
39	MC20000040	VITE M8X50 TCEI	SCREW M8x50 DIN912	VIS M8x50 DIN912	SCHRAUBE M8x50 DIN912	6
40	MC02000016	RONDELLA 8 DIN125	WASHER 8DIN125	RONDELLE 8 DIN125	SCHEIBE 8DIN125	6

Po	Codice/ Code/ Code/ Kennziffer	Denominazione	Denomination	Dénomination	Bezeichnung	Qt.
41	FD04703006	COLONNETTA ROTAX NEW EXTENSION	DRIVE LUG	ARBRE	PIN	6
42	MC02000017	VITE M5X10 DIN7991 INOX	SCREW M5X10 DIN7991	VIS M5X10 DIN7991	SCHRAUBE M5X10 DIN7991	3
43	FD05523005	SLIP RING MIDWEST	FINAL DISK MIDWEST	DISQUE FINAL MIDWEST	ENDSCHEIBE MIDWEST	1
44	MC02000041	VITE SPEC 3/8" 24x30	SCREW	VIS	SCHRAUBE	6
45	FD07223004	ADATTATORE	ADAPTER	ADAPTEUR		1
46	MC02000019	INGRASSATORE	GREASER	GRASSEUR		3
47	MC02000020	RONDELLA 5 IN125 INOX	WASHER 5 IN125 INOX	RONDELLE 5 IN125 INOX	SCHEIBE 5 IN125 INOX	15
49	MC02000023	GRANO M5X50 INOX	SOCKET SET SCREW	VIS SANS TETE	GEWINDESTIFT	3
50	MC02000024	DADO M5 AUTOBL. INOX	NUT M5 INOX	ECROU M5 INOX	MUTTER M5 INOX	15
51	MC02000002	LINGUETTA PER FILO	LOCK WIRE			2
52	FD02253003	BATTUTA 26	BUSHING	BAGUE	BUCHSE	3
53	MC02000050	VITE M4X25 DIN912	SCREW M4x25	VIS M4x25	SCHRAUBE M4x25	2
55	MC00000049	GRANO M5X25 INOX	SOCKET SET SCREW	VIS SANS TETE	GEWINDESTIFT	6
56	FD02253002	BATTUTA VITE	BUSHING	BAGUE	BUCHSE	1
57	MC02000048	GRANO M4X4 INOX	SOCKET SET SCREW	VIS SANS TETE	GEWINDESTIFT	3
58	FD02253001	RONDELLA RITEGNO SPACCO SU VITE	WASHER	RONDELLE	SCHEIBE	1
59	MC02000045	GRANO M4X25 INOX	SOCKET SET SCREW	VIS SANS TETE	GEWINDESTIFT	6
60	MC02000047	RONDELLA 4 IN125 INOX	WASHER 4 IN125 INOX	RONDELLE 4 IN125 INOX	SCHEIBE 4 IN125 INOX	6
61	MC02000043	DADO M4 AUTOBL. INOX	NUT M4 INOX	ECROU M4 INOX	MUTTER M4 INOX	8
62	MC02000046	GRANO M4X15 INOX	SOCKET SET SCREW	VIS SANS TETE	GEWINDESTIFT	3
63	FD05453001	BOCCOLA	BUSHING	BAGUE	BUCHSE	3
64	MC02000039	VITE M5X25 DIN912 INOX	SCREW M5x25 DIN912 INOX	VIS M5x25 DIN912 INOX	SCHRAUBE M5x25 DIN912 INOX	6
65	MC07015003	O-RING mm 82	O-RING mm 82	O-RING mm 82	O-RING mm 82	3
66	FD12203001	CHIAVE PER GHIERE	RINGS TOOL			1
67	FD12203002	CHIAVE CON SPINE	PINS TOOL			1
68	MC02000056	ELICOIL M8	ELICOIL M8	ELICOIL M8	ELICOIL M8	6
69	EC15000009	FILO TRASMISSIONE				2

* OPTIONAL

12.0 Exploded drawing

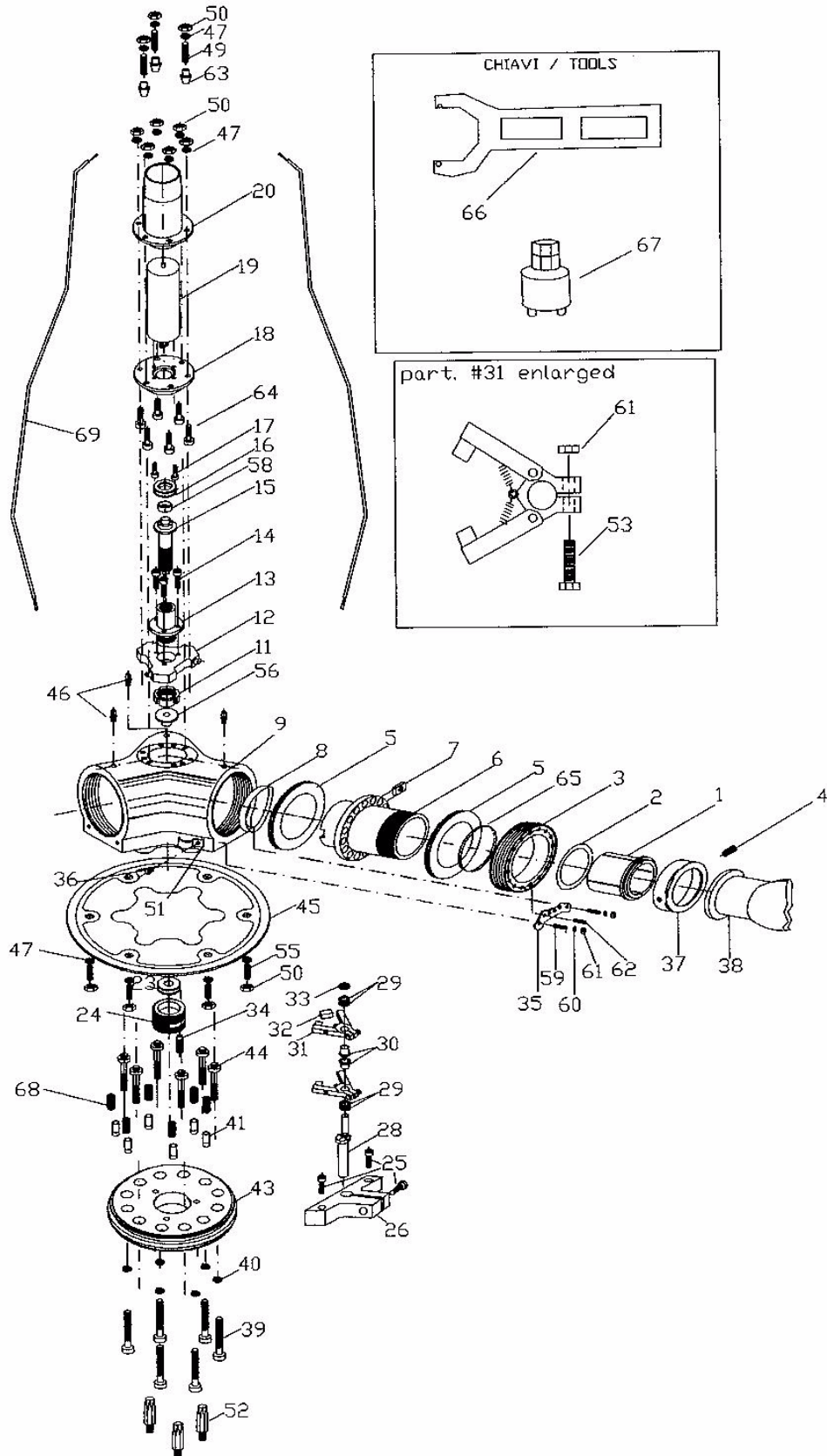

13.0 Torque values

Pos/teil number 36		8 Nm = 5.84 lbs/ft
Pos/teil number 48		13 Nm = 9.5 lbs/ft
Pos/teil number 42		13 Nm = 9.5 lbs/ft
Pos/teil number 25 (if 6 mm)		15 Nm = 10.96 lbs/ft
Pos/teil number 25 (if 5 mm)		13 Nm = 9.5 lbs/ft
Pos/teil number 27 (if 8 mm)		25 Nm = 18.27 lbs/ft
Pos/teil number 27 (if 6 mm)		15 Nm = 10.96 lbs/ft
Pos/teil number 39		25 Nm = 18.27 lbs/ft
Pos/teil number 44 (if 8 mm)		25 Nm = 18.27 lbs/ft
Pos/teil number 44 (if 3/8)		35 Nm = 25.55 lbs/ft
Pos/teil number 50		8 Nm = 5.9 lbs/ft
Pos/teil number 4		10 Nm = 7.3 lbs/ft
Pos/teil number 3	** about	15 Nm = 10,95 lbs/ft
Pos/teil number 37	** about	87 Nm = 64.11 lbs/ft
Pos/teil number 24	** about	2 Nm = 1.45 lbs/ft
Pos/teil number 34		5 Nm = 3.65 lbs/ft
Pos/teil number 57 (use light glue on)		5 Nm = 3.65 lbs/ft
Pos/teil number 54		8 Nm = 5.84 lbs/ft
Pos/teil number 61		5 Nm = 3.65 lbs/ft

Pos/teil in spare parts manual

** usare solo chiavi speciali

N.B.: il costruttore si riserva la facoltà di apportare modifiche al prodotto in qualsiasi momento e senza preavviso.